

Official use only:	Date received
Payment received	Case Ref:



**THE ROYAL BOROUGH OF KINGSTON UPON THAMES
APPLICATION FOR THE GRANT OF A PAVEMENT LICENCE
BUSINESS AND PLANNING ACT 2020**

A pavement licence permits the licence-holder to place removable furniture adjacent to the premises in relation to which the application is made.

Please complete all questions on the form. If you have nothing to record, please state 'not applicable' or 'none'. If you are completing this form by hand, please write legibly in block capitals using black ink. You may wish to keep a copy of the completed form for your records.

There is a 14 day consultation period for all applications. If an objection is received the council have a further 14 days to determine your application. During this period you will not be able to place any furniture on the public highway.

Part 1 – Applicant details

1. Please state if you are applying for a licence as	<u>I would like to make the payment by Debit Card</u>
An individual	<input type="checkbox"/> please complete section A
A company or other incorporated body	<input checked="" type="checkbox"/> please complete section B

Section A - To be completed by individuals. Applications that do not state home addresses will not be accepted.

2. Full name of applicant N/A

3. Home address (including postcode) N/A
--

4. Date of birth N/A

5. Email address N/A	6. Telephone number N/A
--------------------------------	-----------------------------------

Section B - To be completed only if you wish the licence to be held by a limited company.

7. Name of company IN-TAC (0310) COMPANY LIMITED
--

8. Address of registered office 2 Frederick Street Kings Cross London U.K. WC1X0ND [REDACTED]
--

9. Date of birth [REDACTED]

10. Email address [REDACTED]	11. Telephone number [REDACTED]
--	---

Part 2 – Premises details**1. Trading name of business**

IN-TAC (0310) COMPANY LIMITED

2. Business address (including postcode)

On the pavement South of Turks Boatyard, Thames Side, Kingston upon Thames, KT1 1PX

3. Business email address

[REDACTED]

4. Business telephone number

[REDACTED]

5. Which of the following is the above premises used for? (please tick one of the following options)Use as a **public house, wine bar or other drinking establishment** Other use for the **sale of food or drink for consumption on or off the premises** **Both** of the above uses **Part 3 – Proposed activity****1. Location** please provide a description of the area of the highway to which this application relates:
(please note you are required to submit a scale plan of this area with your application)

On the pavement South of Turks Boatyard, Thames Side, Kingston upon Thames, KT1 1PX
 I would like to place 5 tables and 10 chairs in this area. The space I occupy is 4500mm long and 2100mm wide.
 (please refer to my attachment)

2. Relevant purpose Which of the following relevant purposes do you wish to put furniture on the highway for?
(please tick one of the following options)**To sell or serve food or drink**
supplied from, or in connection with relevant use of, the premisesFor the purpose of **consuming food or drink**
supplied from, or in connection with relevant use of, the premises**Both** of the above purposes **3. Days and times you wish to place furniture on the highway on each of the following days**
(please use the 24hr clock)

Monday	Start time:	Finish time:
Tuesday	Start time: 09:00	Finish time: 16:00
Wednesday	Start time: 09:00	Finish time: 16:00
Thursday	Start time: 09:00	Finish time: 16:00
Friday	Start time: 09:00	Finish time: 16:00
Saturday	Start time: 09:00	Finish time: 16:00
Sunday	Start time:	Finish time:

4. Furniture to be placed on the highway please provide a description of the furniture you propose to place on the highway (please note you are required to provide photographs or brochures of the proposed furniture with your application)

I plan to place the tables, the chairs, rubbish bin and tent or parasol. It includes:
5 rectangle tables (size is 60cm x 62cm, height is 73cm),
10 round chairs (diameter is 32cm, height is 45cm),
1 rubbish bin with lid (50 L) and
1 tent or parasol (size is 3m x 2m)
(please refer to my attachment)

Part 4 – Important Notes

The following MUST be submitted with your application

- a) The appropriate application fee of **£100** (how to pay is detailed below)
- b) Evidence of Public Liability Insurance cover to the minimum value of £5,000,000
- c) A scale plan of the proposed location
- d) Details of the furniture you propose to place on the highway

Part 4- Signature

The form must be signed by the applicant or their authorised agent.

I understand that I am required to advertise my application by placing a notice at the premises that can be read by passing members of the public for the full consultation period.

I understand my application will not be considered complete until all the required documents and information have been provided and the application fee paid.

I wish to apply for a pavement licence and confirm that the information given by me on this form is correct. I realise that giving false information could lead to prosecution and the loss of any licence granted.

Signature:



Print Name:
PO LING CHAN

Date:
30/10/24

Freedom of information

The Freedom of Information Act gives people the right to obtain information held by public authorities unless there are good reasons to keep it confidential. Please be aware that information supplied on this form may be released in response to a freedom of information request. To comply with financial regulations, details of license holders may also be disclosed to authorised Government agencies.

IN-TAC (0310) location and design of place tables and chairs

(Application for Pavement Licence)

I have temporary street trading licence for my food stall, I would like to apply for a Pavement Licence to place tables and chairs. Below is my planning.

Location: Thames side (KT11PX)



Location of my Food Stall and place tables and chairs

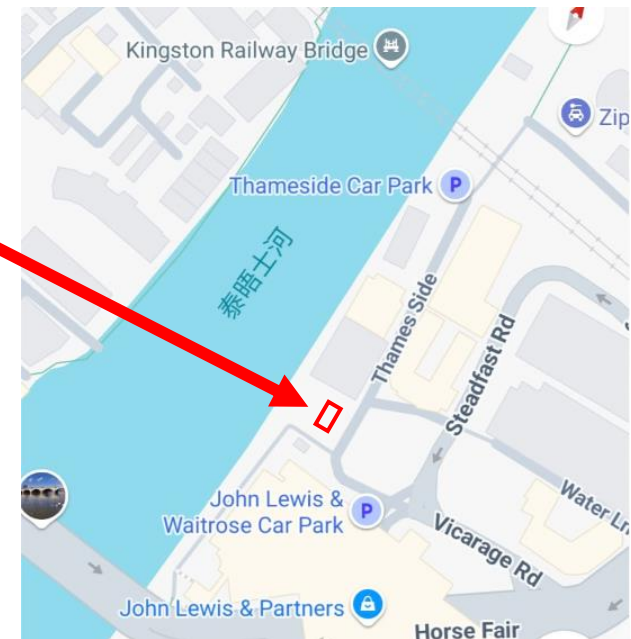

My furniture :

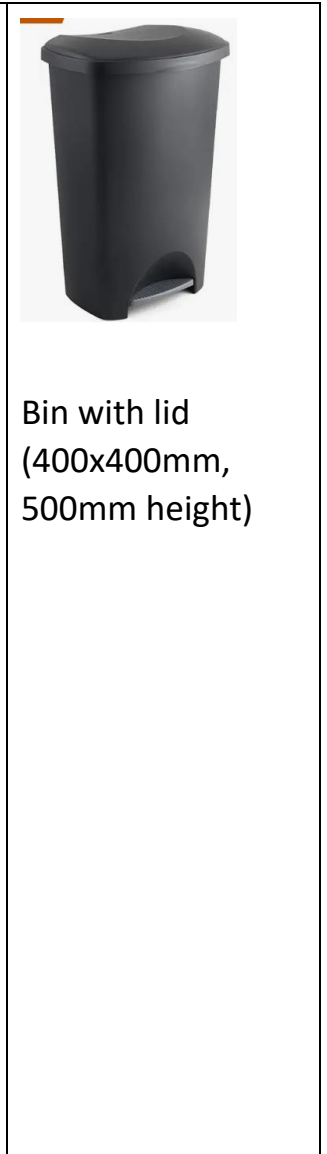
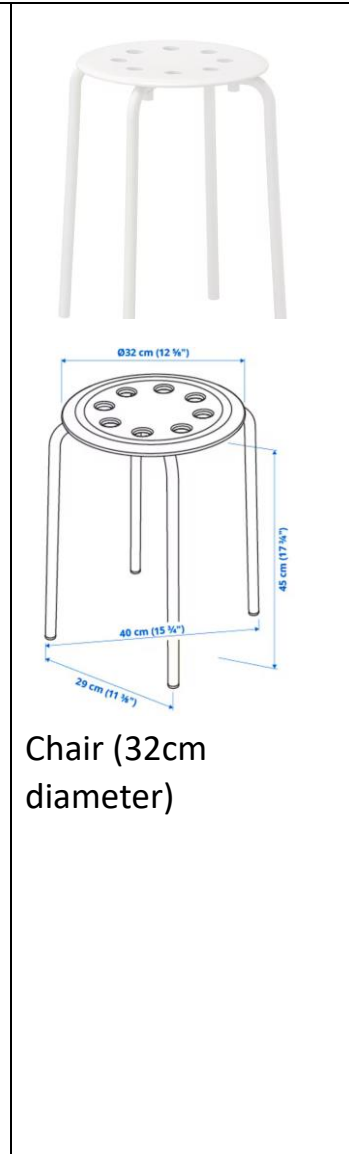

Flooring plan

My food stall (already have a street trading licence)

Planning to place table and chair (currently applying for pavement licence)

River side

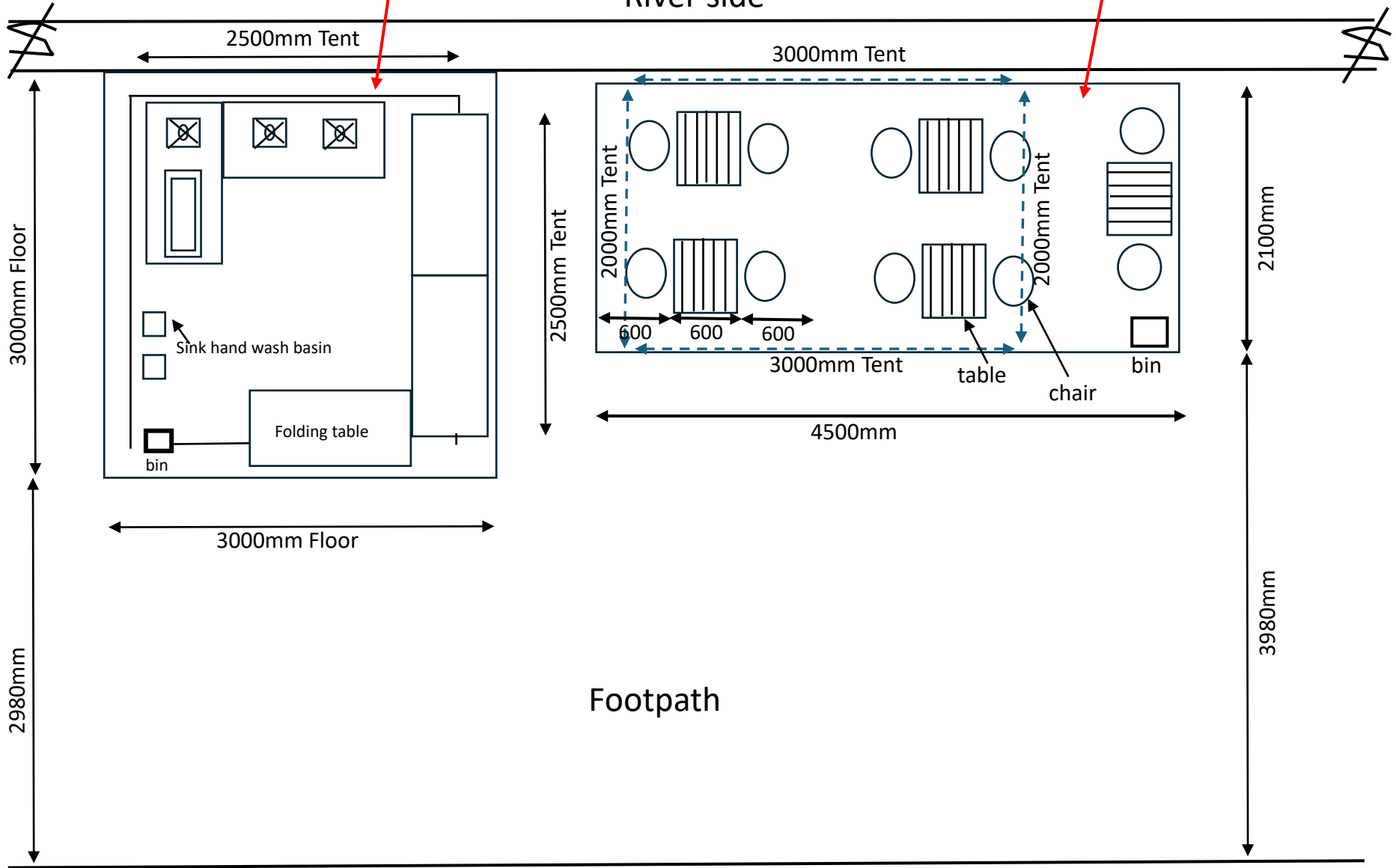

Footpath

Thames Side