

Cambridge Road Estate
 Figure 5.2 Neighbourhood Active Travel Zone

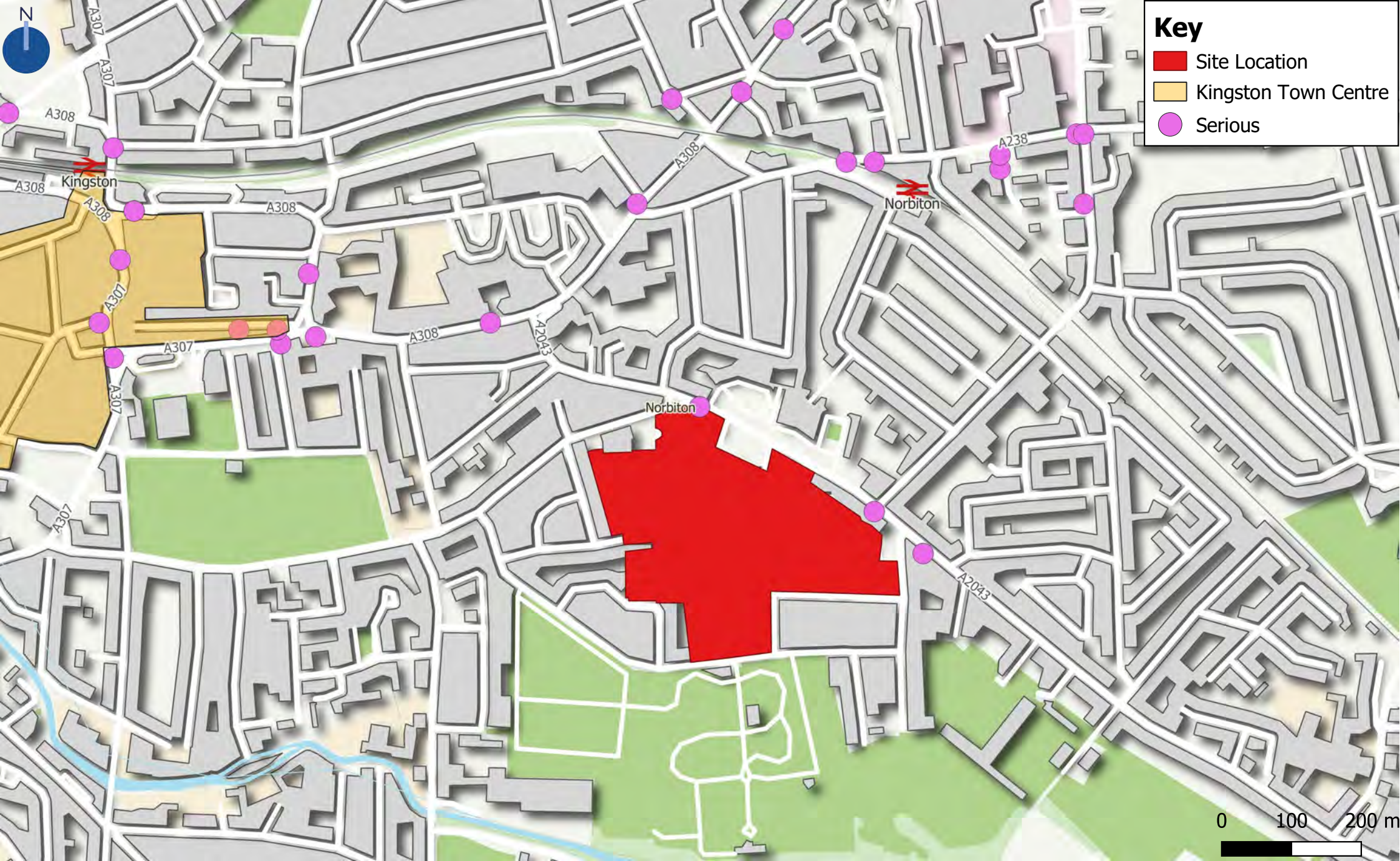

Cambridge Road Estate
Figure 5.3 KSI Plan by Severity

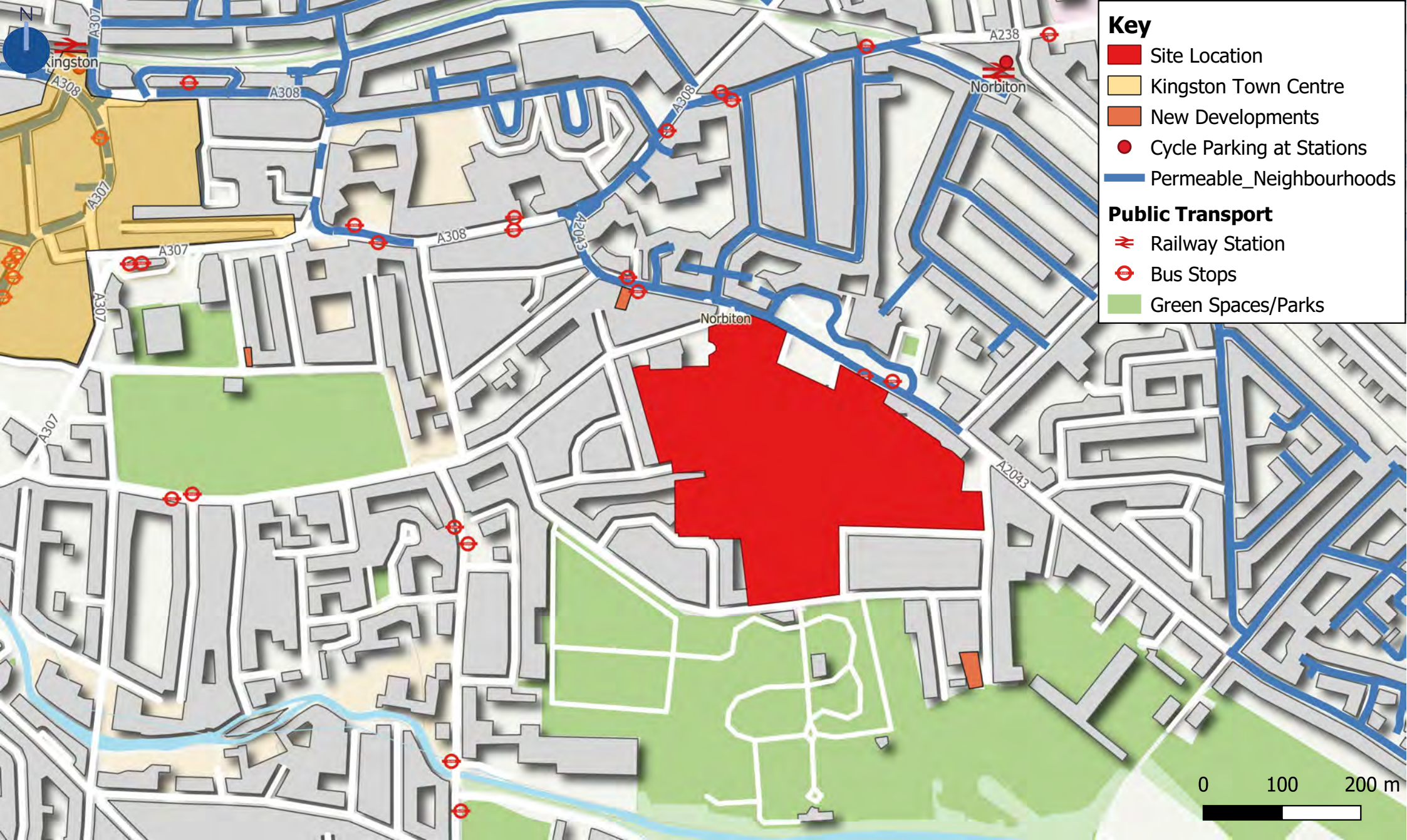

Cambridge Road Estate
 Figure 5.3 ATZ Neighbourhood Health
 Characteristics Check

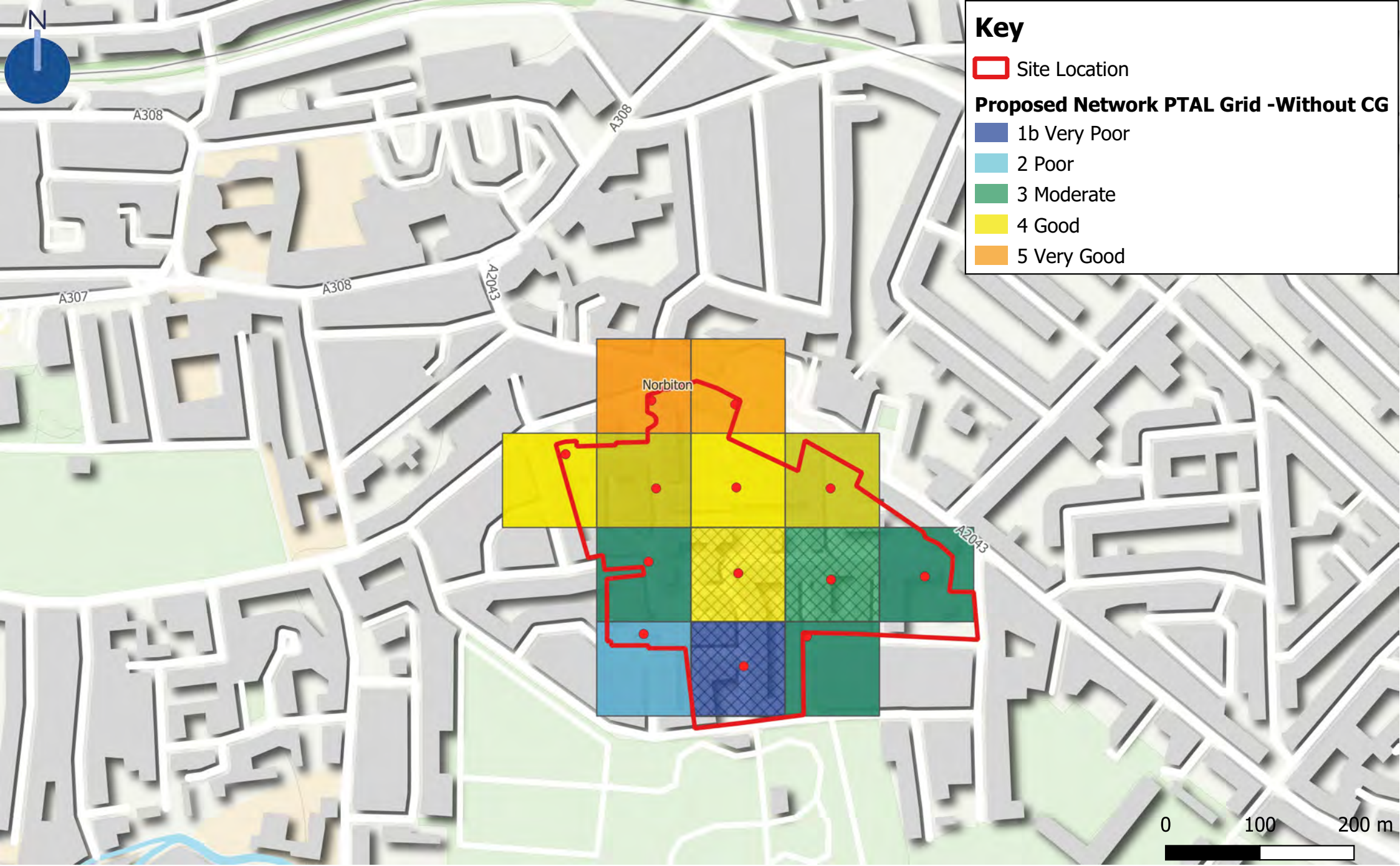

Cambridge Road Estate

Figure 6.1 Proposed Network Without Cambridge Gardens

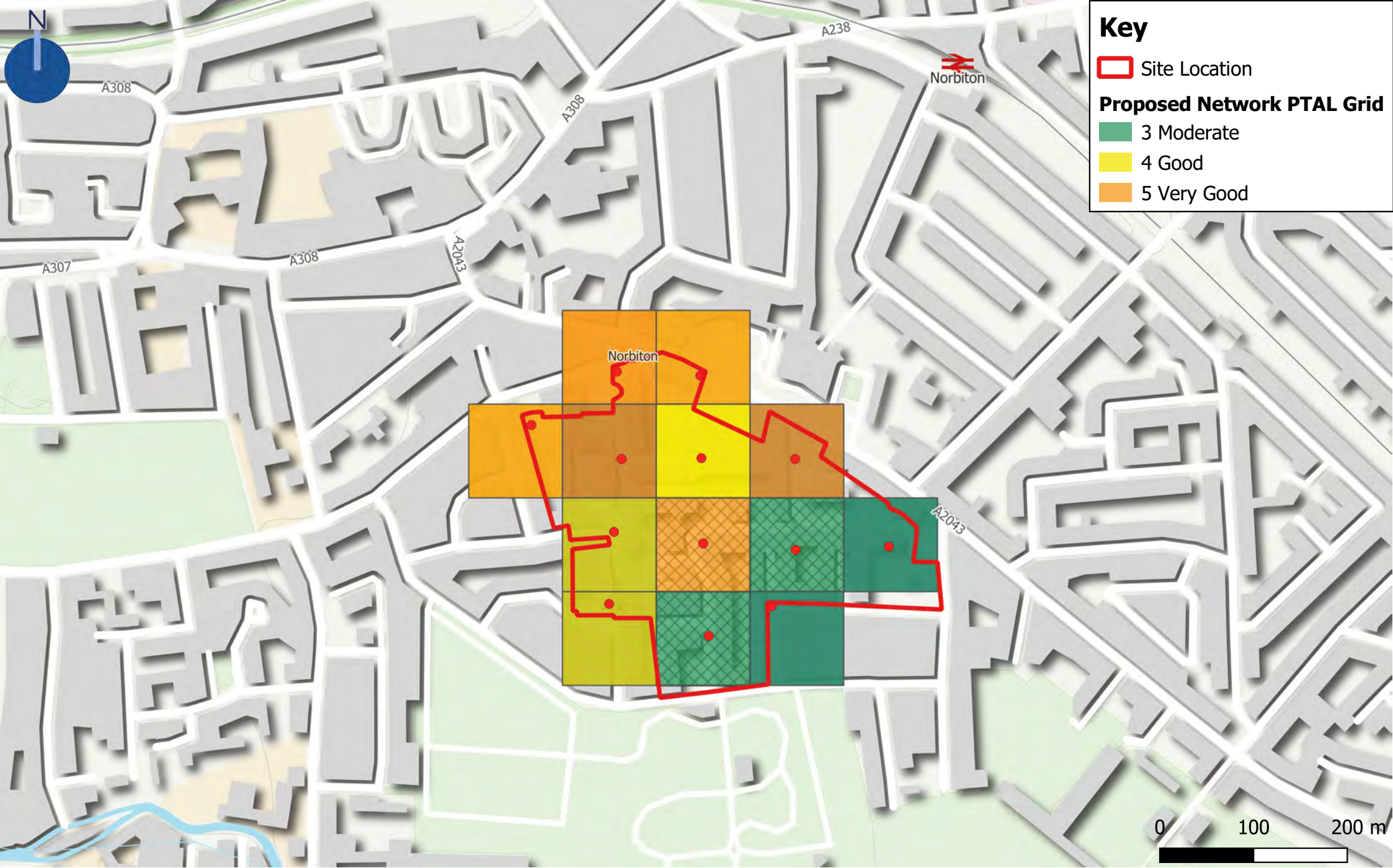

Cambridge Road Estate

DRAWINGS

Drawing 19157-MA-XX-XX-DR-C-0050 – P01: Existing Highway Extent

Drawing 19157-MA-XX-XX-DR-C-0051 – P01: Proposed Stopping Up Area

Drawing 19157-MA-XX-XX-DR-C-0100 – P01: Visibility Splay (Block C Access)

Drawing 19157-MA-XX-XX-DR-C-0101 – P01: Refuse Vehicle (Blocks B & E)

Drawing 19157-MA-XX-XX-DR-C-0102 – P01: 7.5t Box Van (Blocks B & E)

Drawing 19157-MA-XX-XX-DR-C-0103 – P01: Panel Van (Blocks B & E)

Drawing 19157-MA-XX-XX-DR-C-0104 – P01: Fire Appliance (Blocks B & E)

Drawing 19157-MA-XX-XX-DR-C-0105 – P01: Visibility Splay (Block B & E Access)

Drawing 19157-MA-XX-XX-DR-C-0106 – P01: Refuse Vehicle (Blocks C)

Drawing 19157-MA-XX-XX-DR-C-0107 – P01: 10 & 12m Rigid (Blocks C)

Drawing 19157-MA-XX-XX-DR-C-0108 – P02: 7.5t Box & Panel Van (Blocks C)

Drawing 19157-MA-XX-XX-DR-C-0109 – P01: Carriageway Amendments (Blocks C)

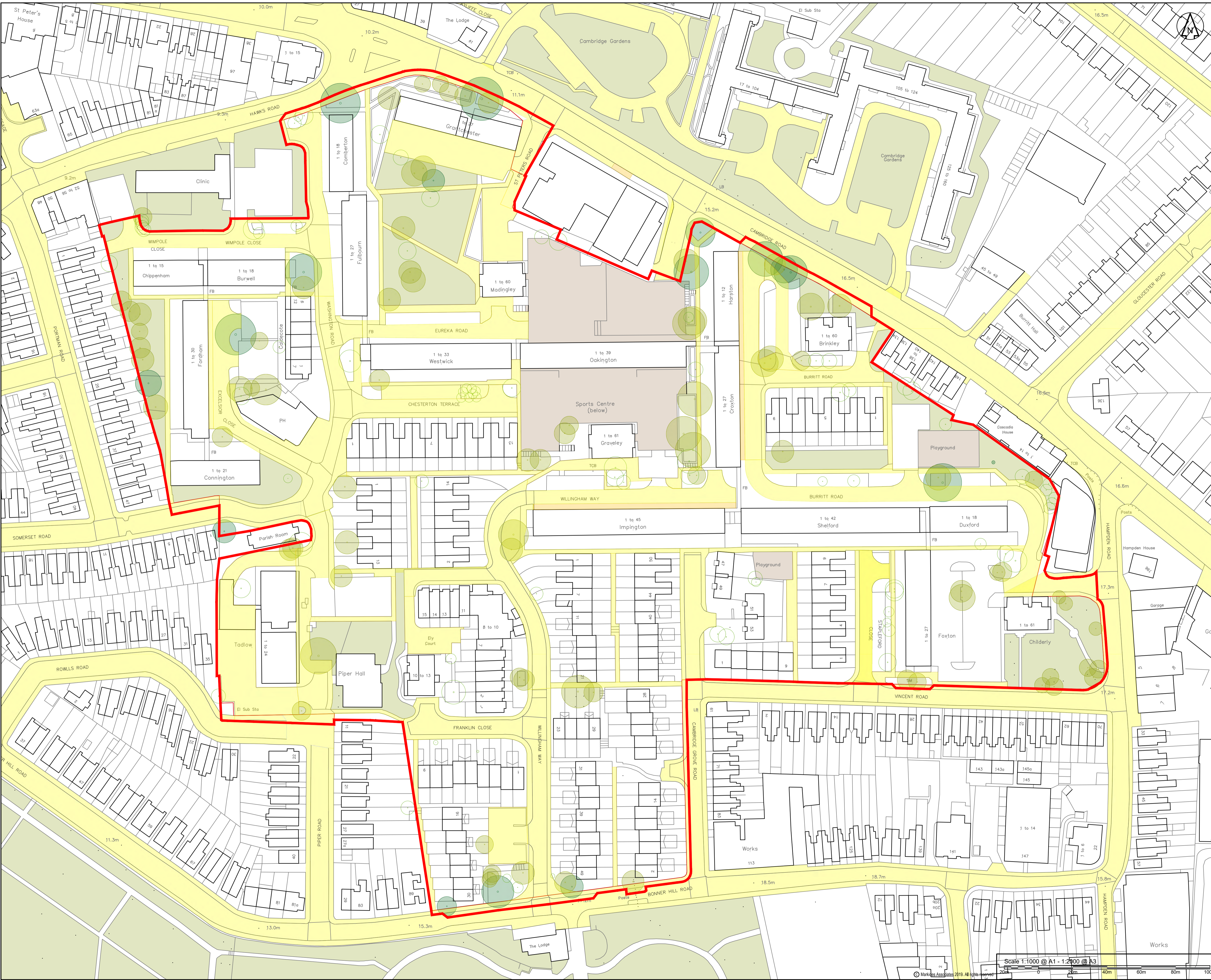

DO NOT SCALE OFF THIS DRAWING

KEY:

- PUBLIC HIGHWAY
- PRIVATELY MAINTAINED
- SITE BOUNDARY

| Revision History | | | | | | |
|------------------|-----------------|---------|-----|------|------|----------|
| Rev | For Information | Comment | CDT | EJ | EJ | Date |
| P01 | FOR INFORMATION | | CDT | EJ | EJ | 12.11.20 |
| Rev | | | By | Chkd | Appr | Date |
| Current Revision | | | | | | |
| P01 | FOR INFORMATION | | CDT | EJ | EJ | 12.11.20 |
| Rev | | | By | Chkd | Appr | Date |

S2 - FOR INFORMATION

CAMBRIDGE ROAD (RBK) LLP



Project: **CAMBRIDGE ROAD ESTATE**

Drawing Title: **PUBLIC HIGHWAY EXTENT**

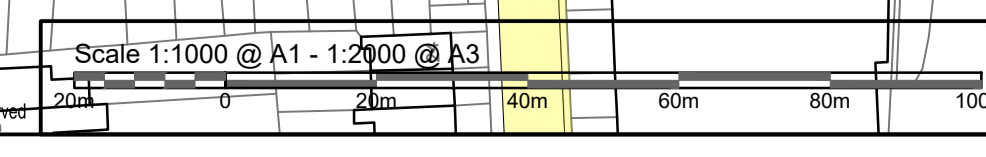

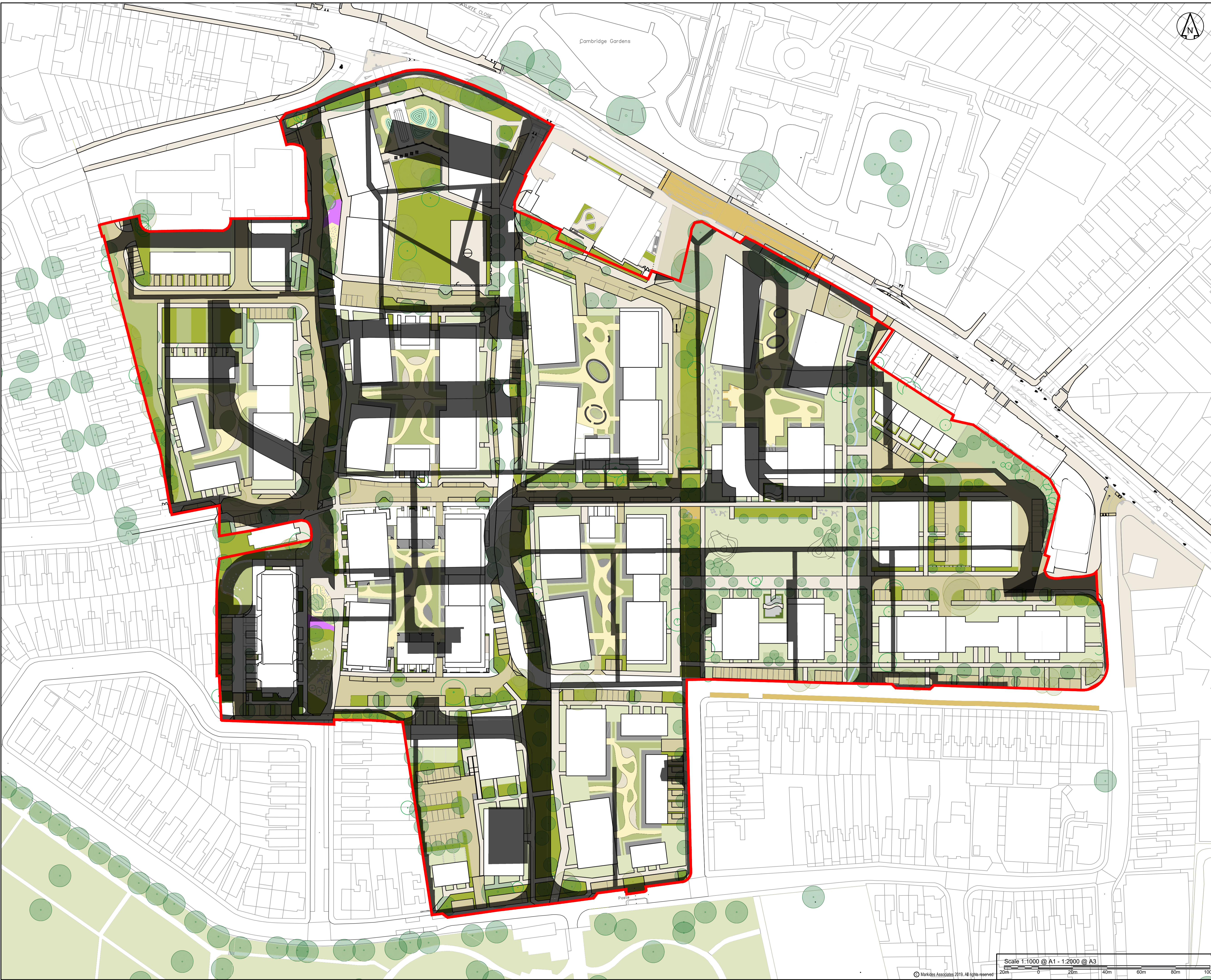

DO NOT SCALE OFF THIS DRAWING

KEY:

HIGHWAY TO BE STOPPED UP
15997m²

SITE BOUNDARY

| Revision History | | | | | | |
|------------------|-----------------|-----|------|------|------|----------|
| Rev | Comment | CDT | EJ | EJ | Appr | Date |
| P01 | FOR INFORMATION | | | | | 12.11.20 |
| Rev | Comment | By | Chkd | Appr | | Date |
| Current Revision | | | | | | |
| P01 | FOR INFORMATION | | | | | 12.11.20 |
| Rev | Comment | By | Chkd | Appr | | Date |

S2 - FOR INFORMATION

CAMBRIDGE ROAD (RBK) LLP



Project
CAMBRIDGE ROAD ESTATE

Drawing Title
**PUBLIC HIGHWAY EXTENT
ARCHITECT'S PLAN**

Markides Associates reference: 19157-MA-XX-XX 1:750@A1
19157-MA-XX-XX-DR-C-0051 - P01

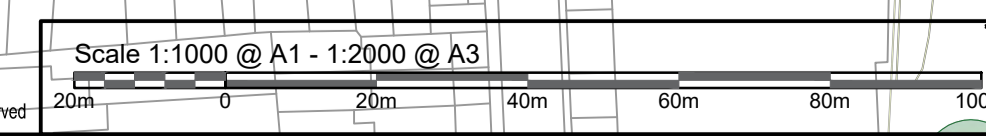

1 to 21
Conington

Parish Room

CYCLE

3B5P (WCH)

PLANT

BIN

ENTRANCE

CYCLE

2B3P (WCH)

3B5P

(93)
3B6P

(102)
4B7P

(115)
4B8P

(124)

3B6P-D

(102)
3B5P

(102)
4B5P-H

(103)
5B8P-H

(134)
4B5P-H

(103)

Plant
Extern
Lobby
Refuse
6B10P

(150)

1B2P

(50)
Refuse
Extern
Lobby
Plant
Store

Cycles
4B6P-H

(112)
5B6P-H

(116)
4B6P-H

(112)
3B6P-D

(102)
3B5P-D

(93)

4B5P-D

(97)
3B6P-D

(102)
1B2P

(50)
Lobby
Refuse

Energy Centre

Indicative
Parking
Layout
Cycle Storage
Substation

Refuse
Lobby
Plant
Storage
1B2P-M4

(55)

3B6P-D

(102)
3B5P-D

(93)

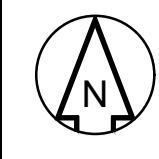

DO NOT SCALE OFF THIS DRAWING

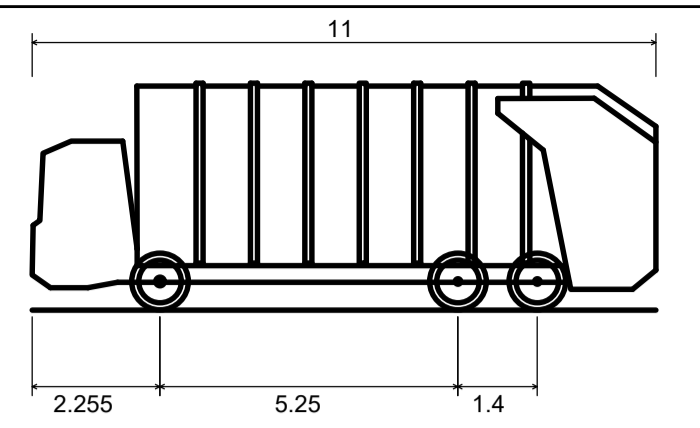

11m Refuse Vehicle
Overall Length 11.000m
Overall Width 2.500m
Overall Body Height 4.000m
Min Body Ground Clearance 0.366m
Track Width 2.450m
Lock to lock time 4.00s
Kerb to Kerb Turning Radius 8.750m

| Revision History | | | | | | |
|------------------|-----------------|---------|-----|------|------|----------|
| Rev | For Information | Comment | CDT | EJ | EJ | 28.10.20 |
| By | Chkd | Appr | By | Chkd | Appr | Date |
| P01 | FOR INFORMATION | | CDT | EJ | EJ | 28.10.20 |
| Rev | Comment | | By | Chkd | Appr | Date |
| Current Revision | | | | | | |
| P01 | FOR INFORMATION | | CDT | EJ | EJ | 28.10.20 |
| Rev | Comment | | By | Chkd | Appr | Date |

S2 - FOR INFORMATION
CAMBRIDGE ROAD (RBK) LLP

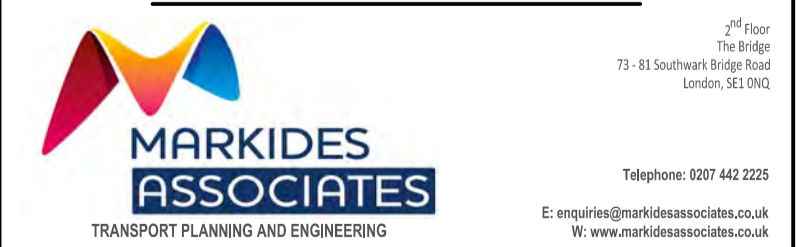

Project
CAMBRIDGE ROAD ESTATE,
KINGSTON
Drawing Title
REFUSE SWEEP PATH ANALYSIS

Markides Associates reference: 191577-MA-XX-XX AS SHOWN
191577-MA-XX-DR-C-0101 - P01

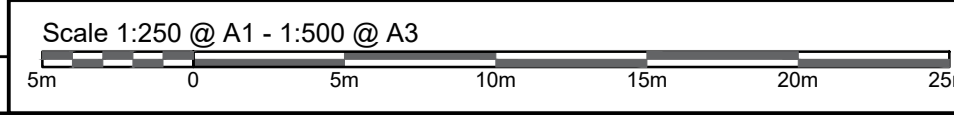

© Markides Associates 2019. All rights reserved

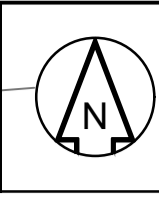

DO NOT SCALE OFF THIS DRAWING

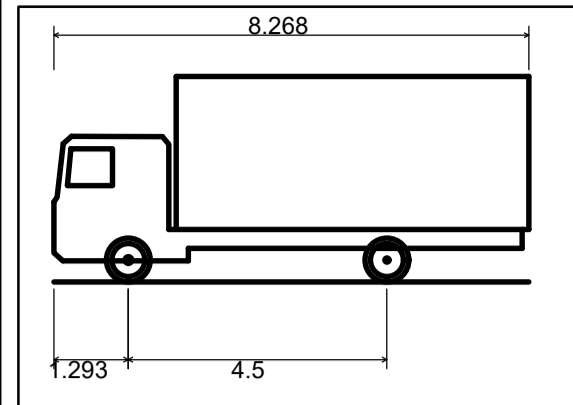

7.5t Box Van (2016)
 Overall Length 8.268m
 Overall Width 2.300m
 Overall Body Height 3.575m
 Min Body Ground Clearance 0.371m
 Track Width 2.176m
 Lock to lock time 4.00s
 Kerb to Kerb Turning Radius 7.500m



| Revision History | | | | | | |
|------------------|-----------------|---------|-----|------|------|----------|
| Rev | For Information | Comment | CDT | EJ | EJ | 28.10.20 |
| By | Chkd | Appr | By | Chkd | Appr | Date |
| P01 | FOR INFORMATION | | CDT | EJ | EJ | 28.10.20 |
| Rev | Comment | | By | Chkd | Appr | Date |
| Current Revision | | | | | | |
| P01 | FOR INFORMATION | | CDT | EJ | EJ | 28.10.20 |
| Rev | Comment | | By | Chkd | Appr | Date |

S2 - FOR INFORMATION
CAMBRIDGE ROAD (RBK) LLP

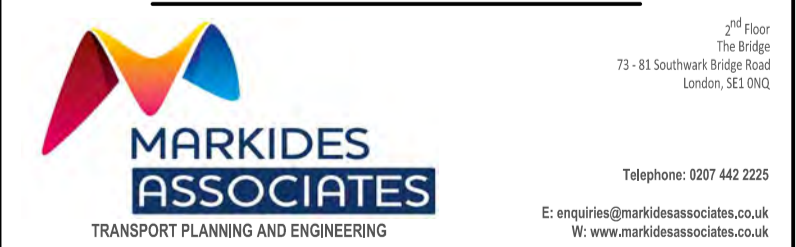

Project
**CAMBRIDGE ROAD ESTATE,
 KINGSTON**

Drawing Title
**BOX VAN
 SWEEP PATH ANALYSIS**

Markides Associates reference: 191577-MA-XX-XX 1:250@A1
 191577-MA-XX-DR-C-0102 - P01

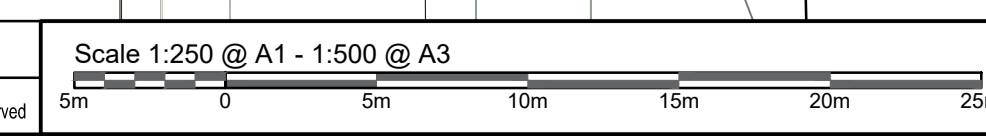

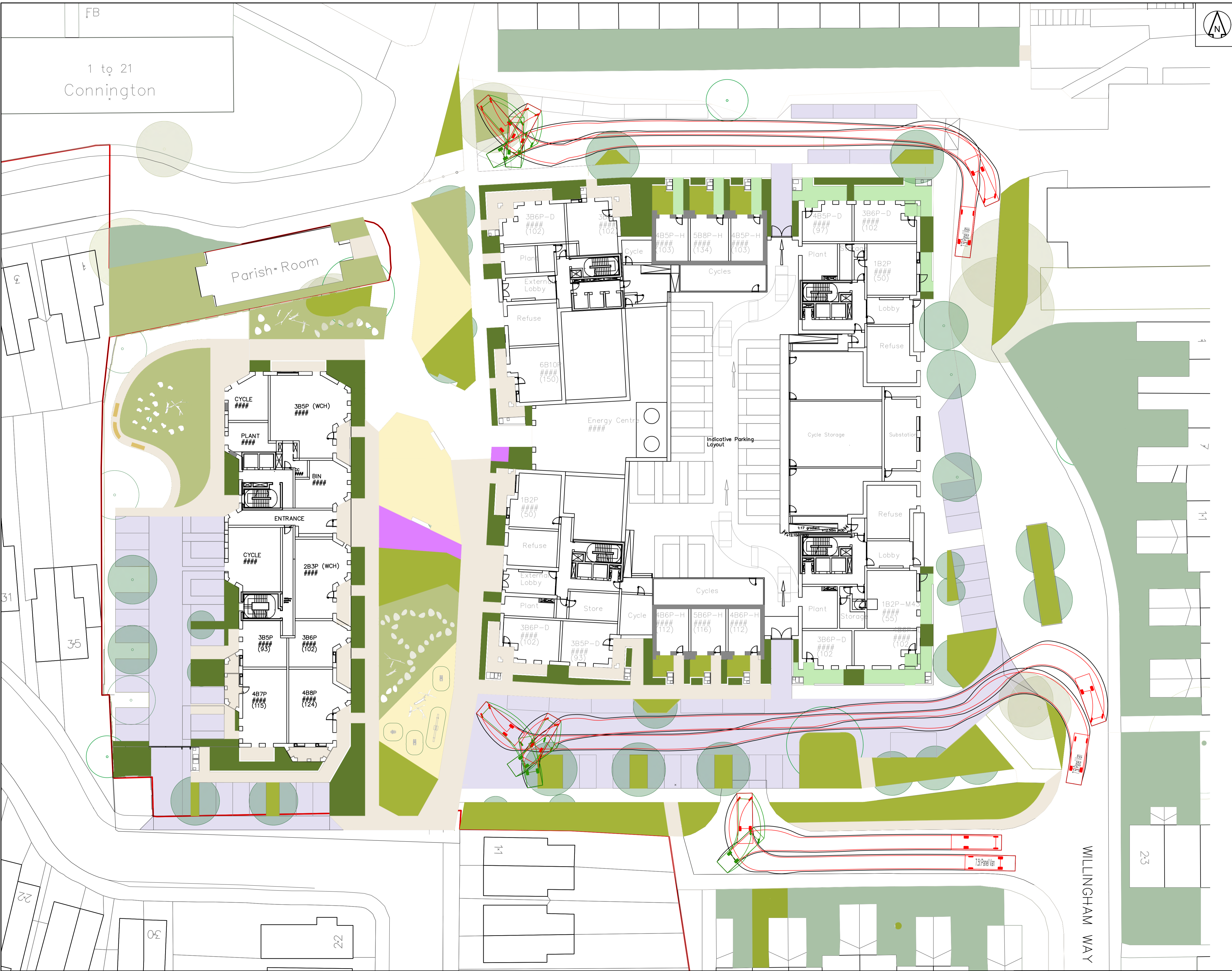

DO NOT SCALE OFF THIS DRAWING

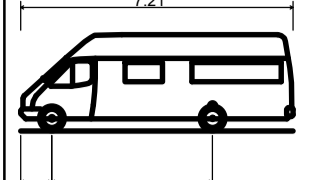
| | |
|--|--------|
|  | |
| 7.5t Panel Van | 7.210m |
| Overall Length | 2.192m |
| Overall Width | 2.544m |
| Overall Body Height | 0.316m |
| Min Body Ground Clearance | 1.865m |
| Track Width | 4.00s |
| Lock to lock time | 7.400m |
| Kerb to Kerb Turning Radius | |

| Revision History | | | | | | |
|------------------|-----------------|--|-----|------|------|----------|
| P01 | FOR INFORMATION | | CDT | EJ | EJ | 28.10.20 |
| Rev | Comment | | By | Chkd | Appr | Date |
| Current Revision | | | | | | |
| P01 | FOR INFORMATION | | CDT | EJ | EJ | 28.10.20 |
| Rev | Comment | | By | Chkd | Appr | Date |

S2 - FOR INFORMATION
CAMBRIDGE ROAD (RBK) LLP



Project: **CAMBRIDGE ROAD ESTATE, KINGSTON**
 Drawing Title: **PANEL VAN SWEEP PATH ANALYSIS**



DO NOT SCALE OFF THIS DRAWING

| | |
|-----------------------------|--------|
| DB32 Fire Appliance | 8.680m |
| Overall Length | 8.680m |
| Overall Width | 2.180m |
| Overall Body Height | 3.452m |
| Min Body Ground Clearance | 0.337m |
| Max Track Width | 2.121m |
| Lock to lock time | 6.00s |
| Kerb to Kerb Turning Radius | 7.910m |

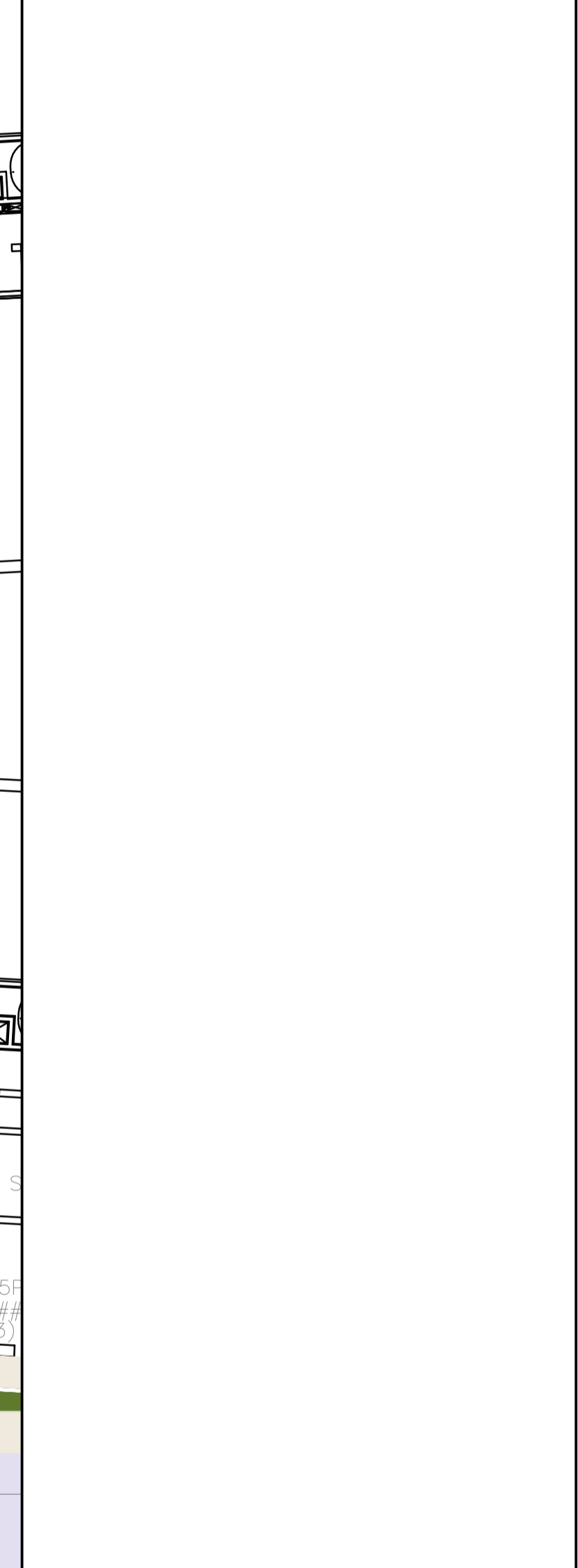

| Revision History | | | | | | |
|------------------|-----------------|---------|-----|------|------|----------|
| Rev | For Information | Comment | CDT | EJ | EJ | 27.10.20 |
| P01 | FOR INFORMATION | | CDT | EJ | EJ | 27.10.20 |
| Rev | Comment | | By | Chkd | Appr | Date |
| Current Revision | | | | | | |
| P01 | FOR INFORMATION | | CDT | EJ | EJ | 27.10.20 |
| Rev | Comment | | By | Chkd | Appr | Date |

S2 - FOR INFORMATION
CAMBRIDGE ROAD (RBK) LLP



Project: **CAMBRIDGE ROAD ESTATE, KINGSTON**
 Drawing Title: **FIRE TENDER SWEEP PATH ANALYSIS**

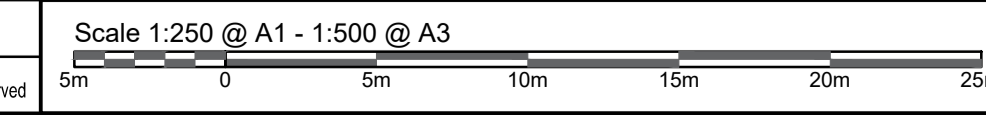

© Markides Associates 2019. All rights reserved

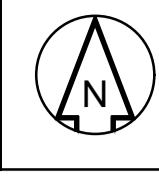

KEY:
VISIBILITY SPLAY



| Revision History | | | | | | |
|------------------|-----------------|----|------|------|----|----------|
| Rev | CDT | EJ | EJ | CDT | EJ | Date |
| P01 | FOR INFORMATION | | | | | 28.10.20 |
| Rev | Comment | By | Chkd | Appr | | Date |
| Current Revision | | | | | | |
| P01 | FOR INFORMATION | | | | | 28.10.20 |
| Rev | Comment | By | Chkd | Appr | | Date |

S2 - FOR INFORMATION
CAMBRIDGE ROAD (RBK) LLP

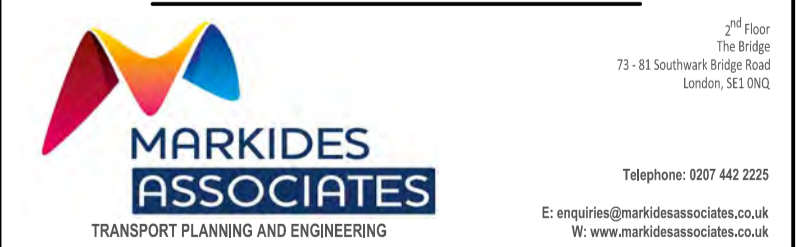

Project
**CAMBRIDGE ROAD ESTATE,
KINGSTON**
Drawing Title
BLOCK C VISIBILITY SPLAYS

