

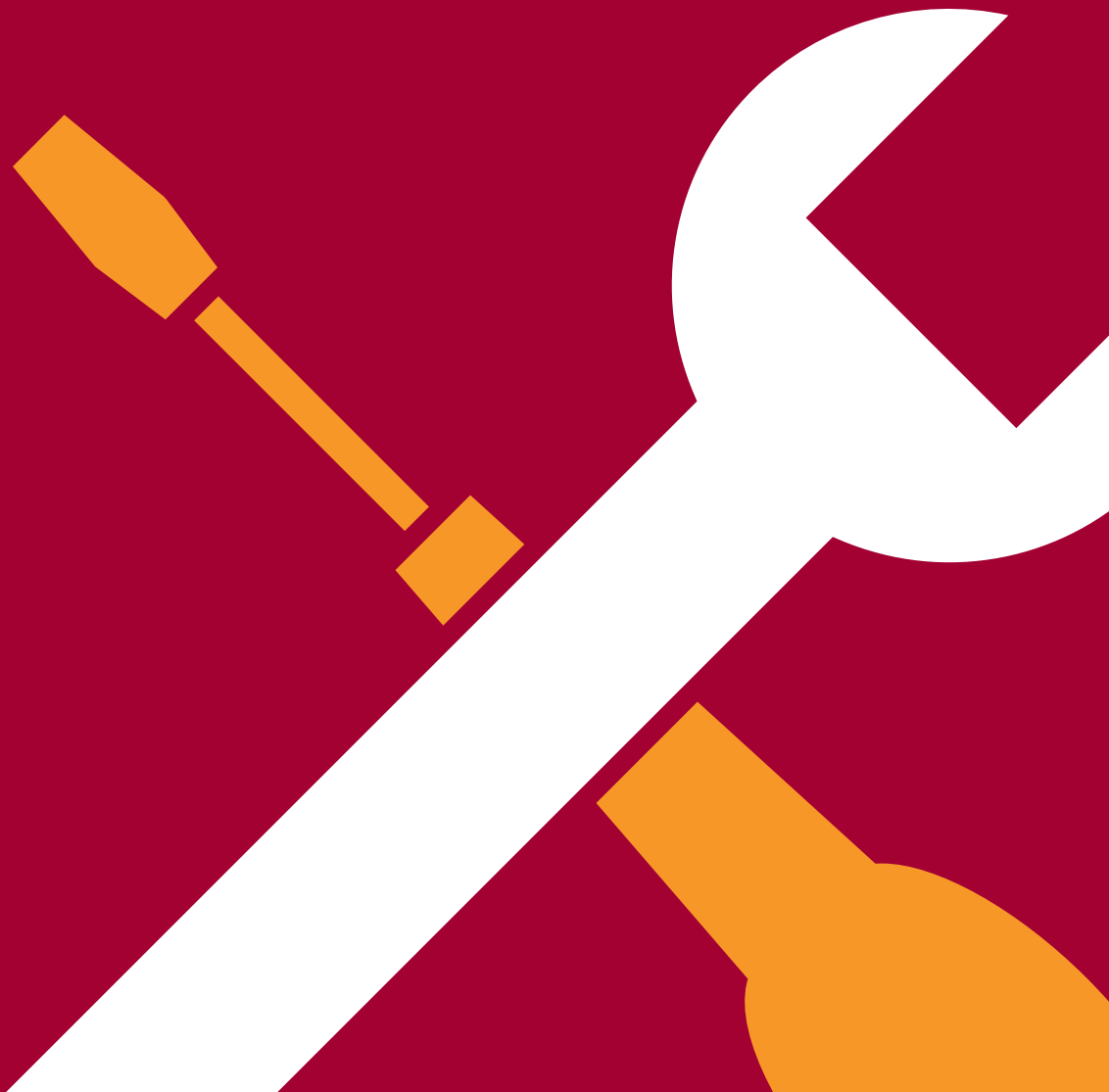

THE ROYAL BOROUGH OF
KINGSTON
UPON THAMES

axis

A handy guide to looking after your home



Handy Guide

Contents



Using this Booklet

How to use this booklet **04**

Health and safety **06**



Plumbing **08**

How to replace a toilet seat **10**

[▶ Watch the video](#)

How to deal with frozen or burst pipes **12**

How to unblock a sink **14**

[▶ Watch the video](#)



Electrics **16**

How to wire a plug **18**

How to reset a trip switch **20**

[▶ Watch the video](#)

How to change a smoke detector back-up battery **22**

How to change a strip light starter or tube **24**

[▶ Watch the video](#)

How to replace a fuse **26**



Locks and Latches **28**

How to adjust a squeaky door **30**

How to adjust a sticking door **32**

How to replace door knobs and handles **34**

[▶ Watch the video](#)

How to replace a mortice latch **36**

[▶ Watch the video](#)

How to fit a door chain **38**

[▶ Watch the video](#)

How to replace a cylinder lock **40**

[▶ Watch the video](#)



Central Heating

42

How to set a digital programmer

44

How to set a time-clock programmer

46

How to control heating temperature

48

How to use a storage heater

50

How to use a panel heater

52

How to look after your heaters

54

How to use heat effectively

55

How to thaw a condensate pipe

56

Freeing up a Thermostatic Radiator Valve Pin

57



Draught Proofing

58

How to fit a brush strip

60

How to fit draught seals

62



Decorating

64

How to fix things to walls

66

 [Watch the video](#)

How to prepare a room for decorating

68

 [Watch the video](#)

How to strip wallpaper

70

 [Watch the video](#)

How to paint

72

 [Watch the video](#)

Mastic baths, basins and sinks

74

 [Watch the video](#)



General Advice

76

How to prevent condensation

78

How to look after your home

80

How to save energy and water

82

How to use this booklet

Whilst the majority of Repairs & Maintenance in your social housing property will be covered by your landlord and undertaken by Axis, there are some things that are down to you.

This booklet will help you to look after your home and undertake activities not covered by your contract. In here you will find DIY tasks to make your home safer, suggestions on what action to take in an emergency – like a leak and step-by-step guidance on how to add ‘personal touches’ to your home.



You don't need to be Nick Knowles, Tommy Walsh or 'Handy Andy' to take on these jobs and you won't need any specialist tools. With just a basic tool kit and a bit of practice, you'll be able to complete these jobs with ease.

With all DIY jobs, preparation is everything. When taking on a job, always follow these guidelines:

- Read the Health and Safety section of this booklet and those supplied with the tools and materials you are using.
- Check that you have everything you need before you start (you can tick off the diagrams in this booklet to help with this).
- Read through the step-by-step instructions and top tips before you begin. Keep them handy while you do the job, so you can refer to them as needed.
- Try to start jobs first thing in the morning. You're less likely to annoy the neighbours if you work during the day, and you can nip out to buy anything you didn't realise you would need.

All information in this booklet is for guidance only. The Royal Borough of Kingston and Axis Europe PLC accept no responsibility for any injury you may incur or damage to property caused by undertaking the DIY tasks in this booklet. You are advised to always have appropriate household insurance cover. If you need help organizing this contact Kingston Council.

Health and safety

Protective clothing

Even simple DIY jobs can lead to injuries or health problems if you don't work safely. Before you start a job, always consider whether or not you need any of the following:

- Overalls (largely to protect your day-to-day clothing)
- Gloves
- Goggles
- Ear protectors
- Dust mask

Always check the manufacturer's instruction when using tools or other items (e.g. oil, paint) as they may recommend particular protective clothing and will include any relevant safety advice.

Asbestos

Before you start any DIY job, make sure you are not going to disturb something that might contain Asbestos. Drilling, cutting or breaking materials that contain Asbestos can lead to serious health problems.

Once a common building material, Asbestos may be present in many fixtures and fittings within your home (e.g. cladding, pipe insulation, textured wall or ceiling coatings, floor tiles, toilet seats and cisterns).

If you have any doubts about Asbestos in your home, please contact Royal Borough of Kingston so that we can arrange for a surveyor to check your property.

Gas

What to do if you smell gas

1. Try to identify the source of the smell. Is it a leak or just an appliance that has been left on?
2. **Put out any naked flames and cigarettes, don't use electrical switches near the smell and don't use anything that could cause a spark.**
3. Turn off the gas supply, using the main gas tap (usually located near your meter).
4. Ventilate the area by opening doors and windows.
5. Leave the building, taking everyone present with you.
6. **Once outside, contact National Grid (Gas) on 0800 111 999. Do not call from inside the house. Take your phone outside and call from a safe distance.**

Gas safety tips

- Keep vents in walls and doors clear from obstructions.
- Check gas appliances regularly. Orange flames or stains around the burner are common signs of a fault.
- Always use GasSafe registered engineers when installing new gas appliances. **You must also seek our permission to install new gas appliances.**
- A GasSafe registered engineer will check gas appliances in your home once a year. We arrange this for all appliances present in the property when you moved in, but you are responsible for arranging with Axis checks of any other appliances.

Electrics

- Electrical safety tips
- Never touch wet electrical fittings or exposed wires.
- Use the correct fuses in plugs. The following is a guide to typical fuse sizes, but always check the manufacturer's instructions for your appliances:

Type of fuse	Typical appliances
3 amp (red)	table lamp, radio, clock, stereo, TV*
5 amp (black)	iron, vacuum cleaner, hair drier, video, drill, food mixer, toaster, fridge or fridge freezer, TV*
13 amp (brown)	electric fire, kettle, washing machine, freezer, deep fat fryer, microwave*

* Check appliance instructions.

- Never have more than 13 amps going through one socket. (You can use the information above as a guide.)
- If a socket or switch is faulty, turn it off at the fuse box and contact your landlord or an electrician.
- Check all plugs and cables regularly for exposed wires. Do not use appliances with exposed wires. Either repair or replace the cable or replace the device.

A basic tool kit

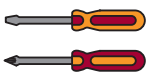

Screwdrivers



Pliers
(with wire-strippers)



Torch



Electric drill
and bits



Plunger



Tape measure



Sink filter

Guide to Plumbing

How to replace a toilet seat	10
How to deal with frozen or burst pipes	12
How to unblock a sink	14





Plumbing Guide

How to replace a toilet seat

Relevant for unblocking kitchen sink, wash hand-basin and shower / bath waste.

Difficulty: 

Time needed: 10 minutes

Tools

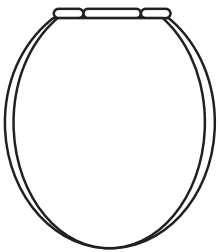

A new toilet seat
(including
mounting bolts)



Large flathead
screwdriver



Pliers

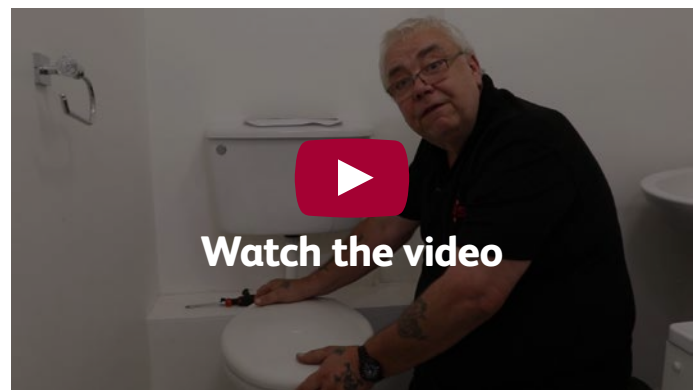

Step-by-Step Instructions

1. Use your screwdriver to pry the plastic covers from the old mounting bolts. (Fig 1)
2. Unscrew the bolts. They will be held in place by nuts underneath the toilet. Grip these with your pliers while you unscrew the bolts. (Fig 2+3)
3. Lift off the old toilet seat and put it to one side.
4. Clean the area around the mounting bolt holes. Make sure this area is dry before you continue.
5. Place the new toilet seat onto the toilet. (Don't forget to remove any adhesive padding from the new seat first.)
6. Thread the mounting bolts through the holes in the toilet and screw on the nuts. Gripping the nuts with your pliers, tighten up the mounting bolts with your screwdriver, just enough to stop the seat from moving, otherwise you could over tighten and crack the toilet.
7. Push the covers on top of the mounting bolts until they snap into place.

(Fig 1)

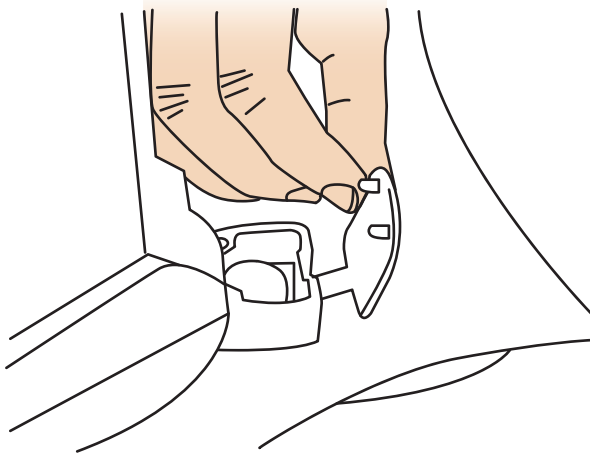

(Fig 2)

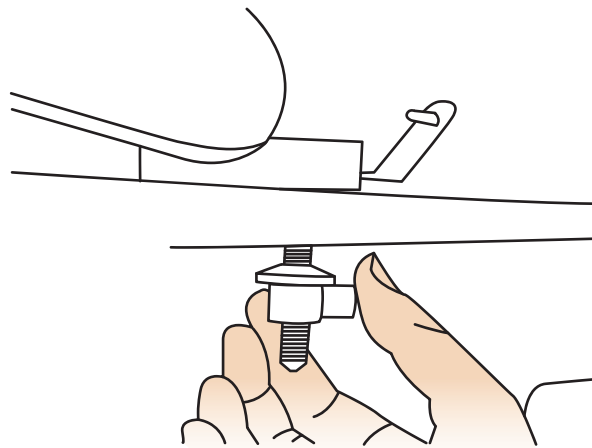
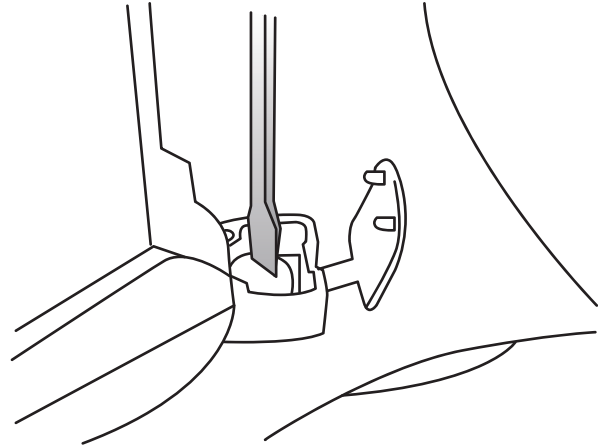

(Fig 3)

Top Tips

- If your toilet seat is loose, try tightening the mounting bolts before buying a new one.
- Toilet seats tend to come in one of two standard sizes. Make sure you measure the old seat to avoid buying one that doesn't fit.
- Make sure the toilet seat comes with mounting bolts. If not, you can use the old bolts (if they aren't damaged) or buy new mounting bolts separately.
- Some toilet seats lower slowly to prevent slamming — great if you have young children.
- You can also buy toilet seats that unlock at the hinge. Being able to remove the seat this way makes cleaning that part of the toilet a lot easier.



Plumbing Guide

How to deal with frozen or burst pipes

Difficulty: ●●○○○

Time needed: Varies

Note:

- Know where your Mains Stop-Tap is located - often under the kitchen sink or cupboard under the stairs

Step-by-Step Instructions

Frozen pipes

1. If water flow from a tap is reduced to a trickle during cold weather, you may have a frozen pipe. You should check all of your taps, as you may have more than one frozen pipe.
2. You can thaw frozen pipes using hot water bottles or towels soaked in hot water. Do not use naked flames, as you could damage the pipe. Do not pour hot water on the pipes, as this will freeze around the pipes when it cools.
3. Running the affected taps should help to thaw the frozen pipes. It will also indicate when normal water pressure has been restored.
4. If you cannot find or reach the frozen pipes, turn off the water supply at the main stoptap and contact a plumber. If the hot water system is frozen, you should also shut down the water heater or boiler.

Burst pipes

You need a plumber urgently but here are some tips to limit damage before they arrive.

1. Turn off the water supply using the main stoptap and shut down your boiler.
2. Drain your water system by turning on every tap in the house.
3. When the water stops running, which may take up to 15 minutes, turn off all the taps.
4. If water is wetting any electrics, turn off your electricity supply at the fuse box/consumer unit immediately. Do not touch wet electrics!
5. If water is leaking upstairs, your ceiling could collapse. You could prevent this by placing buckets under any bulges in the ceiling and piercing them with a screwdriver. The water will drain through this hole, which might save your ceiling.

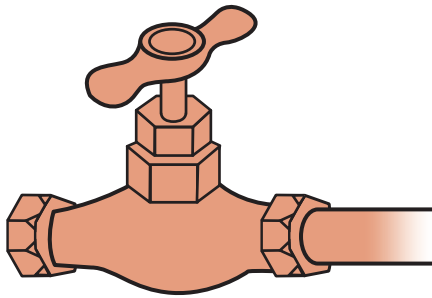

Stoptap

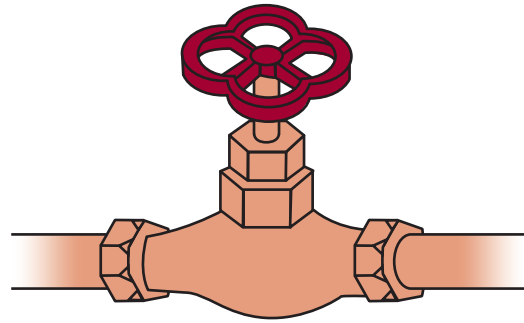

Gatevalve

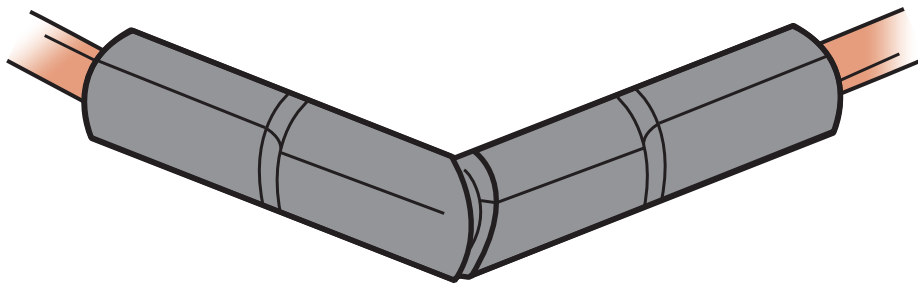

Pipe lagging

Top Tips

- The best way to prevent frozen or burst pipes is to make sure your pipes are insulated (i.e. lagged). Remember, you don't need to insulate under water tanks, as heat should rise from below to keep them warm.
- Avoid coming home from a winter break to burst pipes by draining your water system before you go away.
- Just in case, make sure you know where to find your main stoptap and the gatevalves for your hot and cold water tanks. In most houses, the stoptap is under the kitchen sink and the gatevalves are near the water tanks. If you can't find them, contact RBK.
- Once you've found the stoptap and gatevalves, make sure that you can turn them easily and check them regularly.



Plumbing Guide

How to unblock a sink

Difficulty: ●●○○○

Time needed: 20 minutes

Tools



Plunger

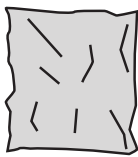

Dishcloth
(wet)

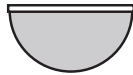

Bowl

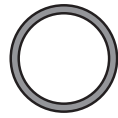

Spare
water trap
sealing rings
(optional)

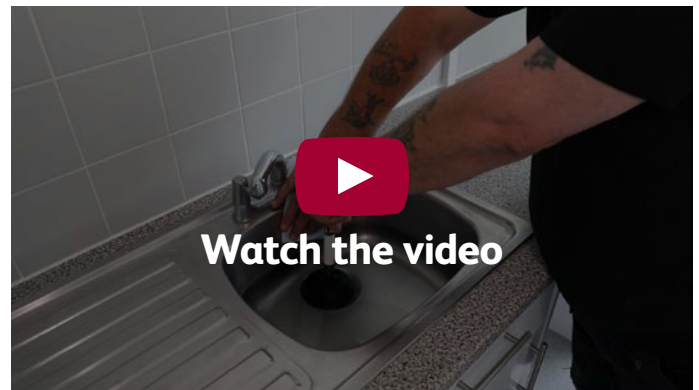

Warning:

- Please refrain from putting food/fat down the sink.
- Also, do not throw nappies, sanitary products, wet wipes or fresheners down your toilet.

Step-by-Step Instructions

1. Use your bowl to get as much water out of the sink as you can.
2. Seal the sink's overflow by firmly holding your dishcloth over it. (Fig 1)
3. Hold the plunger so that its head covers the plughole and is resting against the basin. Make sure there is some water in the basin
4. Quickly thrust the plunger towards the plughole. You may need to do this a few times before the water begins to drain.

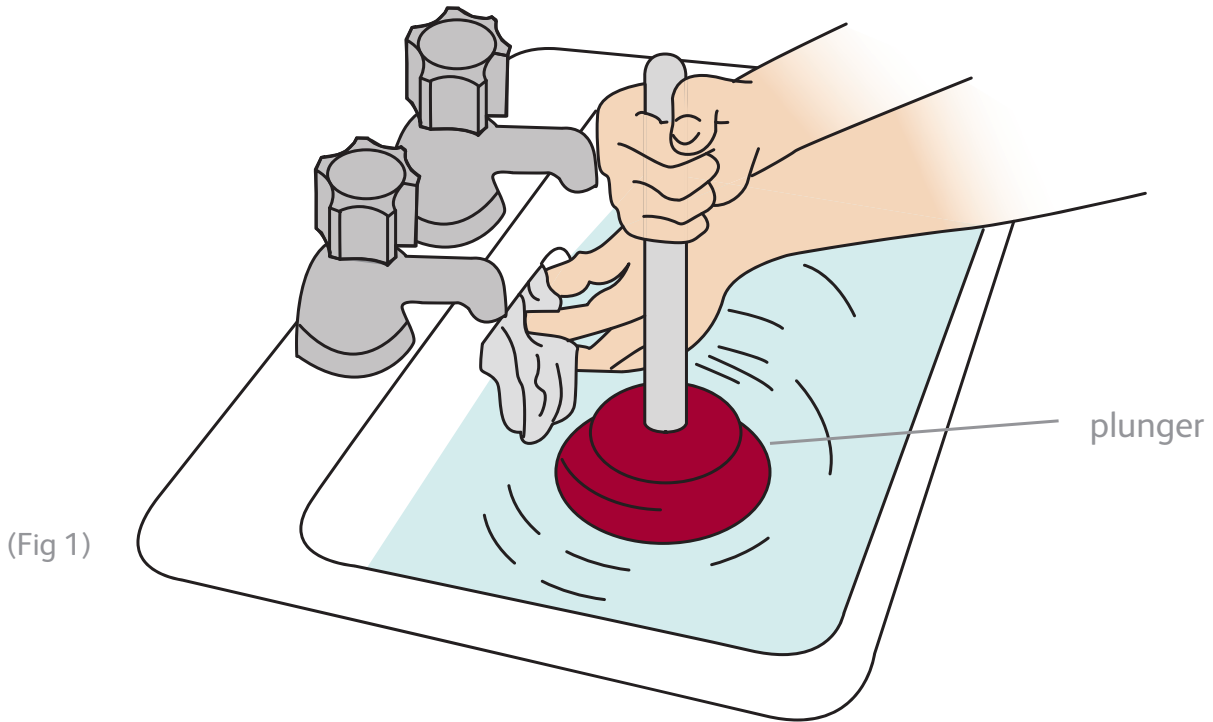

Unblocking a sink

Guide to Electrics

How to wire a plug	18
How to reset a trip switch	20
How to change a smoke detector back-up battery	22
How to change a strip light	24
How to replace a fuse	26





Electrics Guide

How to wire a plug

Difficulty: ● ● ● ○ ○

Time needed: 10 minutes

Tools

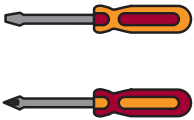

Screwdrivers
(crosshead and flathead)



Pliers
(with wire-strippers)

Note:

- Do not overload circuits with extension leads
- Do not run cables to outside areas

Step-by-Step Instructions

1. Remove plug from power point circuit
2. If your plug is not sealed, use your screwdriver to remove the screw from the centre of the plug, then remove the top of the plug.
3. Loosen the cable grip screws, so that you can twist the cable grip to one side, then loosen the terminal screws and remove the plug's fuse.
4. If the cable is showing signs of heat damage, including hard or brittle wires, cut to remove that section. Use your pliers to strip back the cable's outer sheath by about 5cm. Be careful not to cut the inner wires.
5. Place the cable into the plug head, making sure there is enough cable within the plug head for the cable grip to hold.
6. Line the internal wires up with their terminals (Fig 1), then cut the wires so that they comfortably reach their terminals.
7. Use the wire-strippers to strip 1cm of each coloured wire's insulating sheath. Then, twist the exposed copper wires, and double them over to ensure a snug fit within each terminal.
8. Insert each wire into its terminal (See Fig 1) and tighten the terminal screws so that there is no exposed copper wiring within the plug. Be careful not to push any of the plastic sheath into the terminal.
9. Tighten the cable grip so that the cable is clamped in place. Then insert an appropriate fuse for that appliance.
10. Replace the top of the plug and tighten the plug's central screw.

(Fig 1)

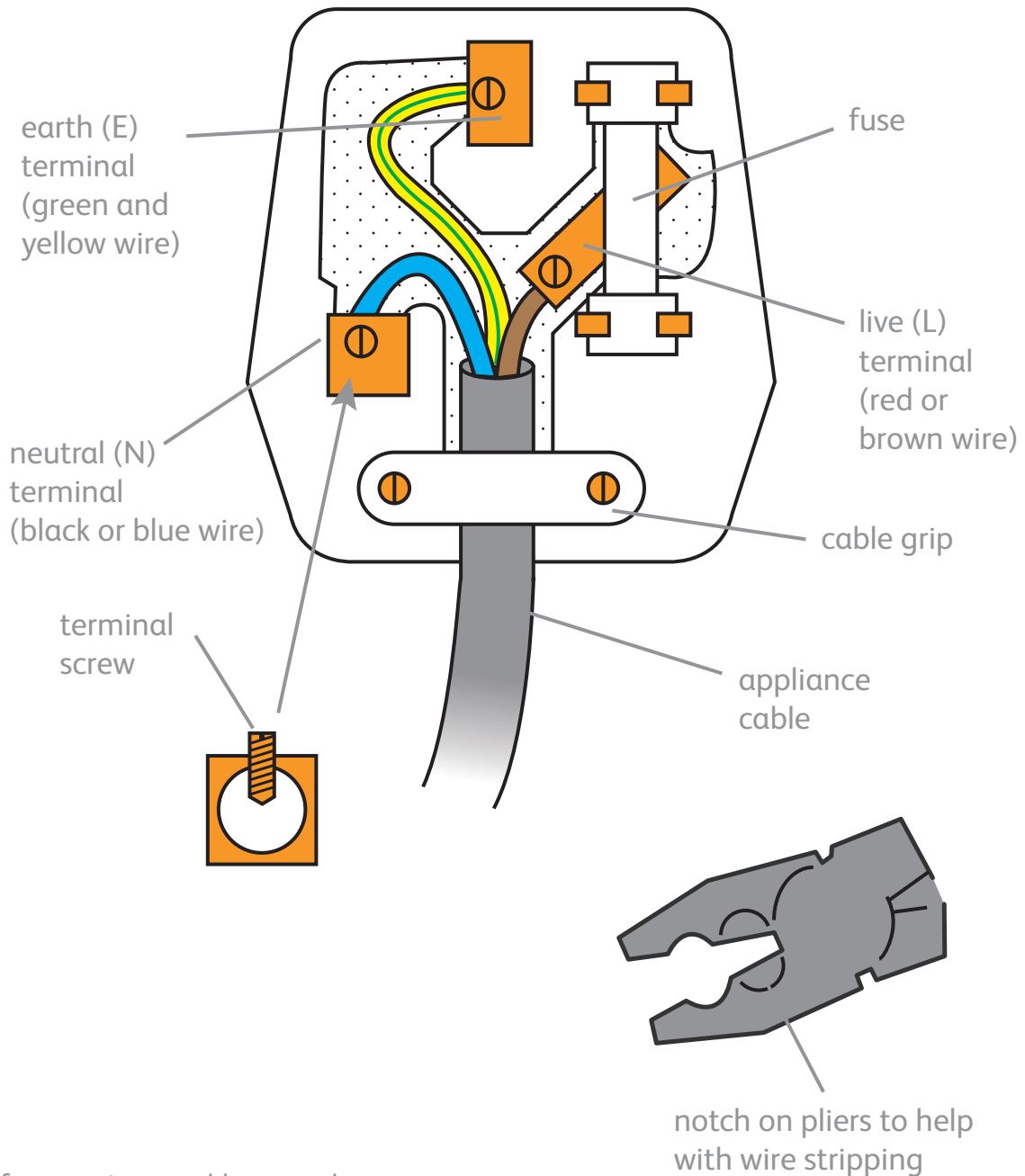

If the fuse continues to blow, gets hot or smells of burning isolate the supply and report to the Royal Borough of Kingston



Electrics Guide

How to reset a trip switch

Difficulty: 

Time needed: 5 to 10 minutes

Tools



Torch



Stepladder

Step-by-Step Instructions

1. Open the fuse box cover. You may need a stepladder and torch for this, as fuse boxes/ consumer units are often placed at height and in poor lighting.
2. Turn off ALL switches at the fuse board starting with the 'main switch'. All switches should be in the down position.
3. Switch off ALL Plug Sockets serving ALL of your Household Appliances & remove ALL Plugs from the Sockets
4. Turn back on the 'main switch'
5. Insert one at a time, one Plug serving an Appliance into it's Socket & switch on. Return to the Fuse Board to see if any of the MCB's or RCD has tripped? If it hasn't tripped, insert another Plug serving an Appliance into it's Socket & switch on. Again, return to the Fuse Board to see if any of the MCB's or RCD has tripped? Repeat this process each time, until either the MCB or RCD trips out. If it does, this will then identify the Appliance which is causing the fault (This will be the most recent Appliance you have plugged in) Turn on the RCD's. There may be one or two of these depending on the fuse box / consumer unit. (If at this point the RCD trips then turn the main switch back off and contact Royal Borough of Kingston for an emergency electrician.)
6. Now switch on each MCB in turn leaving 5 seconds between each. If there is a fault on a particular circuit it will be highlighted when the resident turns on the relevant MCB as the RCD will trip within 40 milliseconds
7. If the RCD trips turn off the last MCB that you turned on and reset the RCD
8. Leave off the MCB that caused the RCD to trip and continue turning on the remaining MCB's until they are all restored with the exception of any that trip the RCD.
9. Check the label on the MCB that caused the trip to identify the circuit (normally located directly below the switch).
10. Leave the fusebox / consumer unit with all MCB's on apart from the faulty one which will restore power to the property apart from the area affected by the faulty circuit
11. If you cannot identify the fault, contact Royal Borough of Kingston for an electrician to repair the faulty circuit. Do not continue using faulty appliances or sockets.

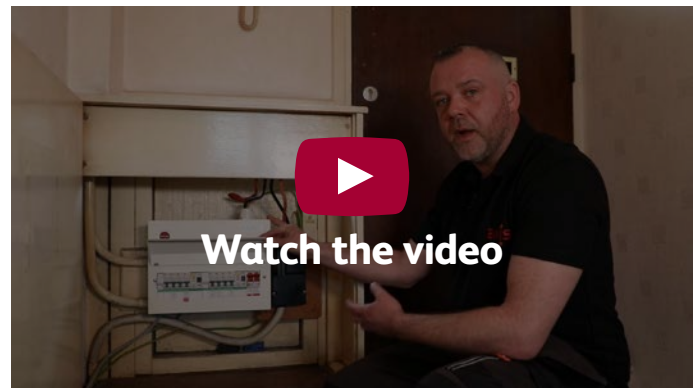

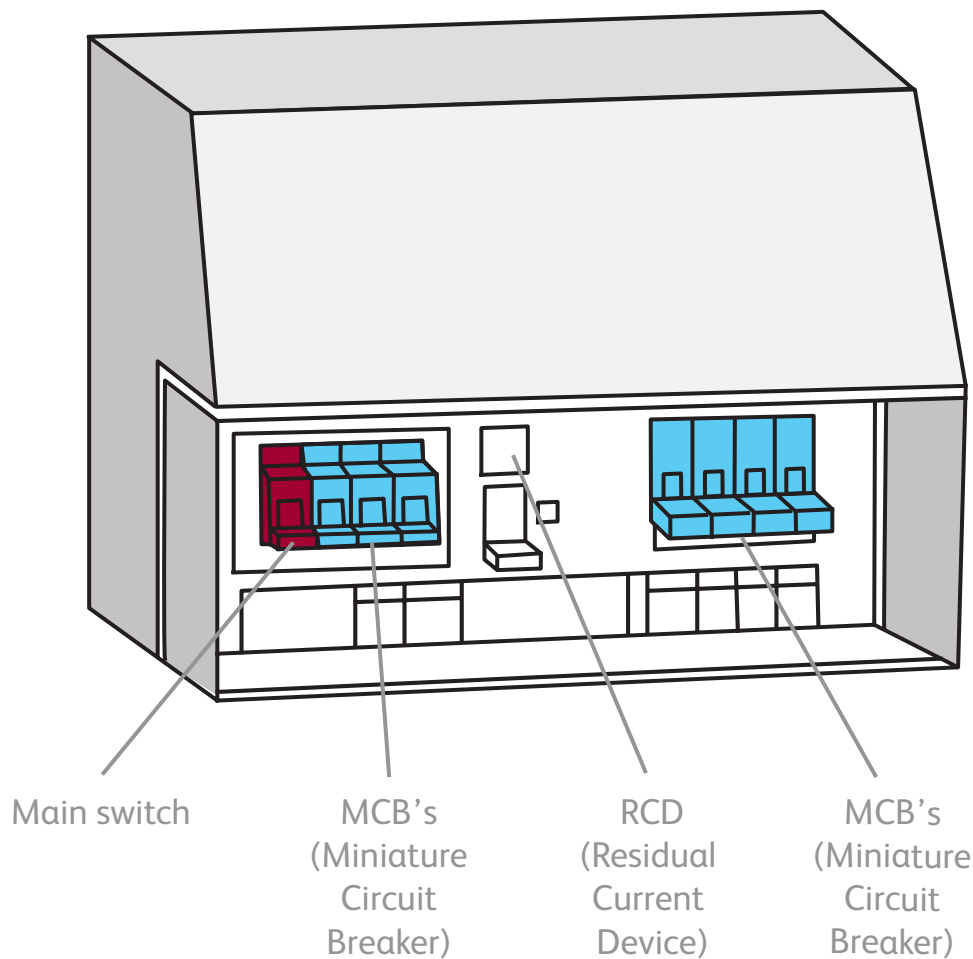

Top Tips

- The 'main switch' controls all power to the consumer unit
- RCD (Residual Current Device) - A safety device which monitors faults on electrical circuits, designed to trip when a fault is detected.
- MCB's (Miniature Circuit Breakers) These control the flow of current to each circuit.
- Fuse boxes/consumer units come in lots of shapes and sizes, but they all share the same basic principles. The main difference is that some use up/down switches, while others use in/out buttons.
- Ordinarily, switches will be in the 'on' position (up for switches, in for buttons). When an electrical fault 'trips' a switch, it snaps into the 'off' position, cutting power to part of your household circuit.
- Sockets and lights have their own switches, helping you isolate faults.
- Common faults include:
 - a 'popped' light bulb
 - too many appliances on one circuit or socket
 - a faulty appliance



Electrics Guide

How to change a smoke detector back-up battery

Difficulty: 

Time needed: 5 minutes

Tools



9V battery



Stepladders

Note:

- Most smoke detectors are hardwired into your homes electricity, but if your smoke detector beeps then check the back-up battery - it could save your life.

Step-by-Step Instructions

1. Remove the smoke detector's cover.
2. Pull the old battery from its retaining clips, then remove it from the battery connectors.
3. Attach the new battery to the connectors and push it into the retaining clips.
4. Replace the smoke detector's cover. To be sure the detector is working, push the test button while you're there.

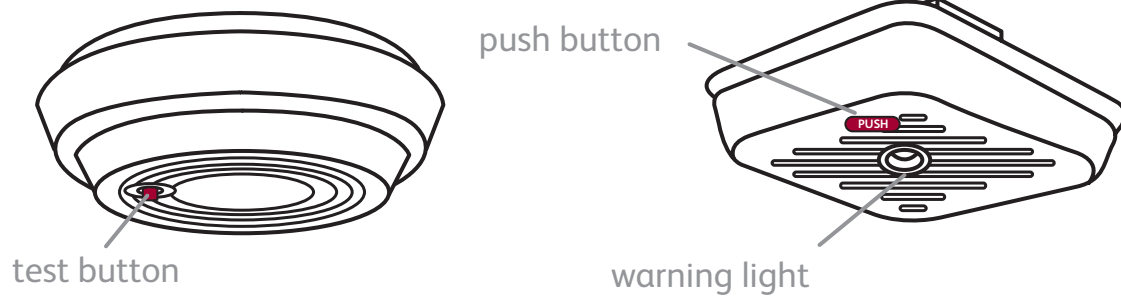

Top Tips

- If a mains operated detector goes off when it shouldn't and you have checked there is no smoke or fire, turn it off at the fuse box and don't turn it back on for at least 5 minutes.
- Use step ladders and not a stool or chair to reach the smoke alarm.



Electrics Guide

How to change a strip light starter or tube

Difficulty: ● ● ● ● ●

Time needed: 10 minutes

Tools



Starter



Fluorescent tube



Stepladders

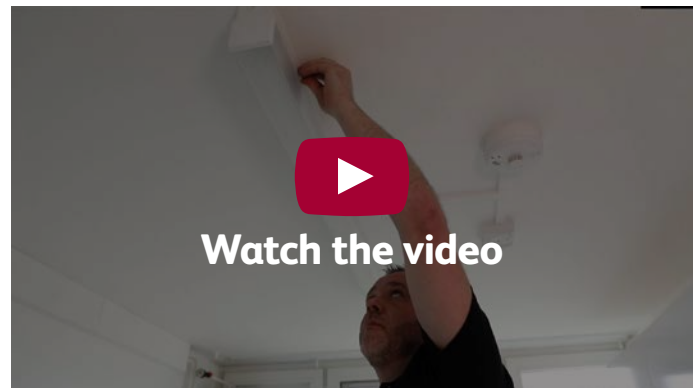

Watch the video

Step-by-Step Instructions

1. It is important to turn off the light at the local switch
2. Some strip lights have diffuser covers. If yours has one, you can release it by pulling away one of the support brackets.
3. To replace a starter, twist the old starter 90 degrees anti-clockwise, then pull it out. Insert the new starter and lock it in place by twisting it 90 degrees clockwise.
4. To replace a fluorescent tube, pull away one end support bracket. Some tubes must be twisted 90 degrees to retract the contact pins. Put the old tube to one side, then put the new tube into position. Again, you might need to twist the tube to lock the contact pins into place.
5. If you have a diffuser cover, replace this now.
6. Old tubes should not be placed in your normal waste. Contact Royal Borough of Kingston for proper disposal options in your area.

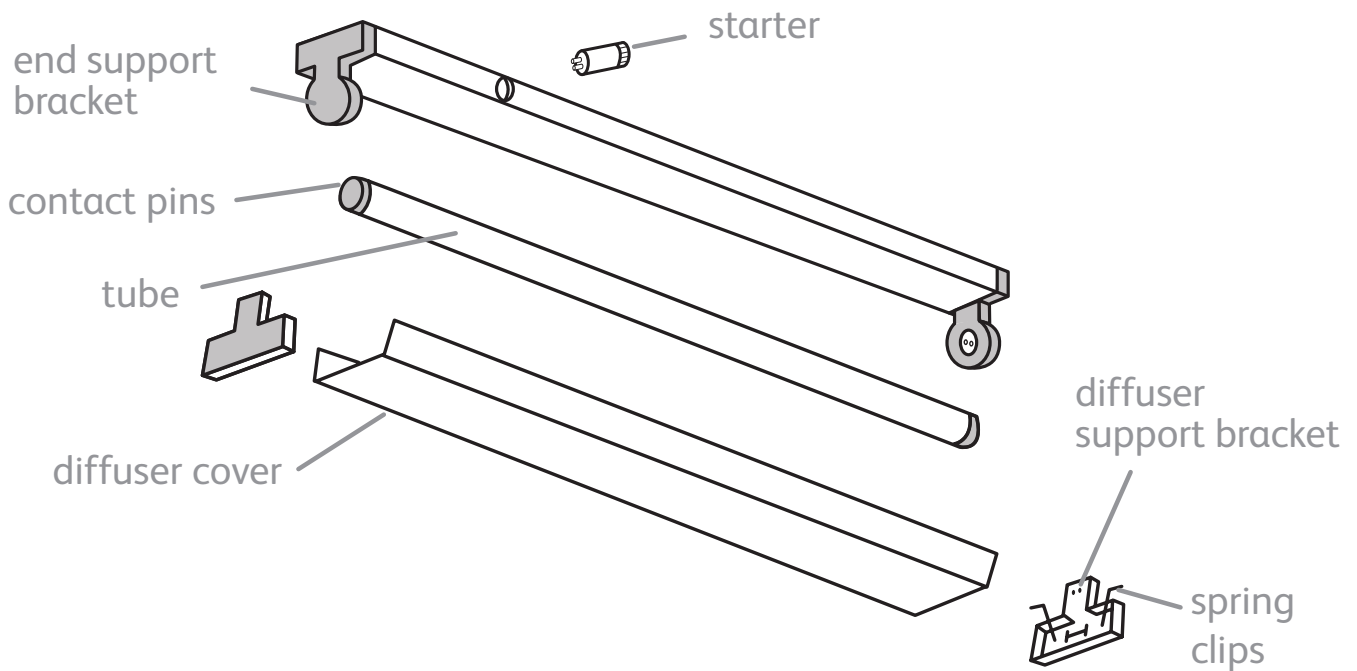

Top Tips

- If a strip light isn't coming on properly, it's usually for one of two reasons:

Type of fault	Action
Flickering or lighting only at the ends	Replace the starter
Dim or shimmering light	Replace the fluorescent tube

- Make sure you measure your fluorescent tube before you buy a new one, as they come in many different sizes.
- Fluorescent tubes cannot be disposed of with the rest of your household waste. You should take spent fluorescent tubes to your local waste recycling centre.
- Use step ladders and not a stool or chair to reach the strip light.



Electrics Guide

How to replace a fuse

Difficulty: ● ● ○ ○ ○

Time needed: 10 minutes

Tools



Screwdrivers
(crosshead and flathead)

Warning:

- If the fuse blows again immediately, it is likely there is a problem. Contact Royal Borough of Kingston

Step-by-Step Instructions

1. Switch off the plug at socket switch.
2. Unplug the item.
3. Look at the underside of the plug where the three prongs are.
4. If there is a fuse holder on the bottom of the plug, gently open it using the tip of a slot-head screwdriver. If not, unscrew the large central screw on the base of the plug and open it up.
5. Remove the fuse using the blade of a slot head screwdriver.
6. Replace with one of the right amperage for the appliance the rating will be written on the fuse.
7. Replace the plug cover and screw tight.

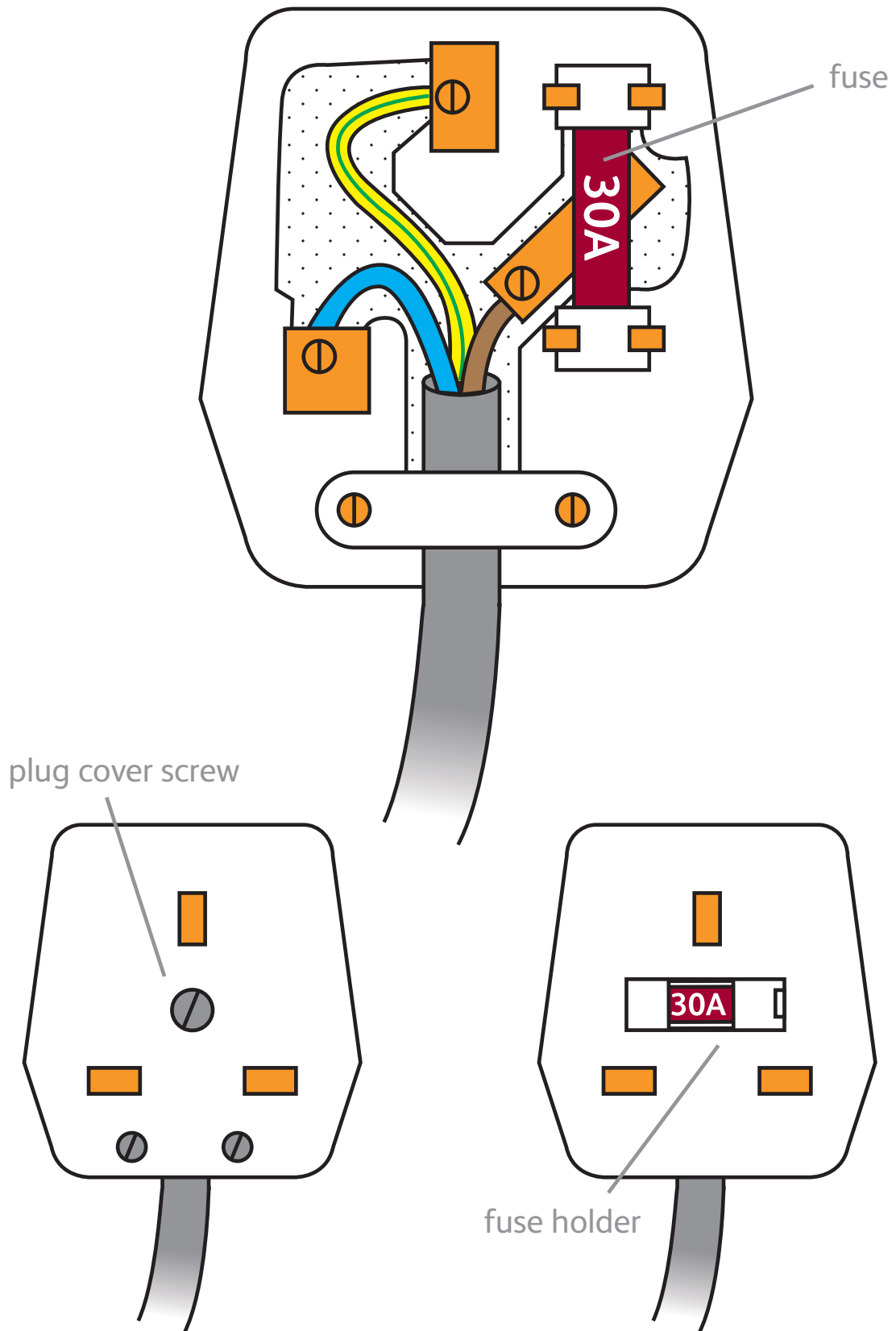

Guide to Locks & Latches

How to adjust a squeaky door	30
How to adjust a sticking door	32
How to replace door knobs and handles	34
How to replace a mortice latch	36
How to fit a door chain	38
How to replace a cylinder lock	40





Locks & Latches Guide

How to adjust a squeaky door

Difficulty: ● ○ ○ ○ ○

Time needed: 5 to 10 minutes

Tools



Oil



Screwdriver (usually flathead)

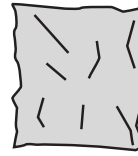

Rag

Step-by-Step Instructions

Squeaky Door

1. Squeeze a drop of oil into the top of each hinge. Protect your flooring and woodwork.
2. Let the oil run into the hinges for a few seconds, then slowly move the door back and forth. As the oil works into the hinge, it should stop squeaking.
3. Clean up any excess oil from the hinge with a rag.

Loose door

1. Wedge the door open wide enough to allow easy access to the hinges. This will keep the door open and at the correct height.
2. Tighten up any loose screws with your screwdriver. You may need to 'pack' some of the screw holes if they are too wide for the screws. Matchsticks or toothpicks will be ideal for this.

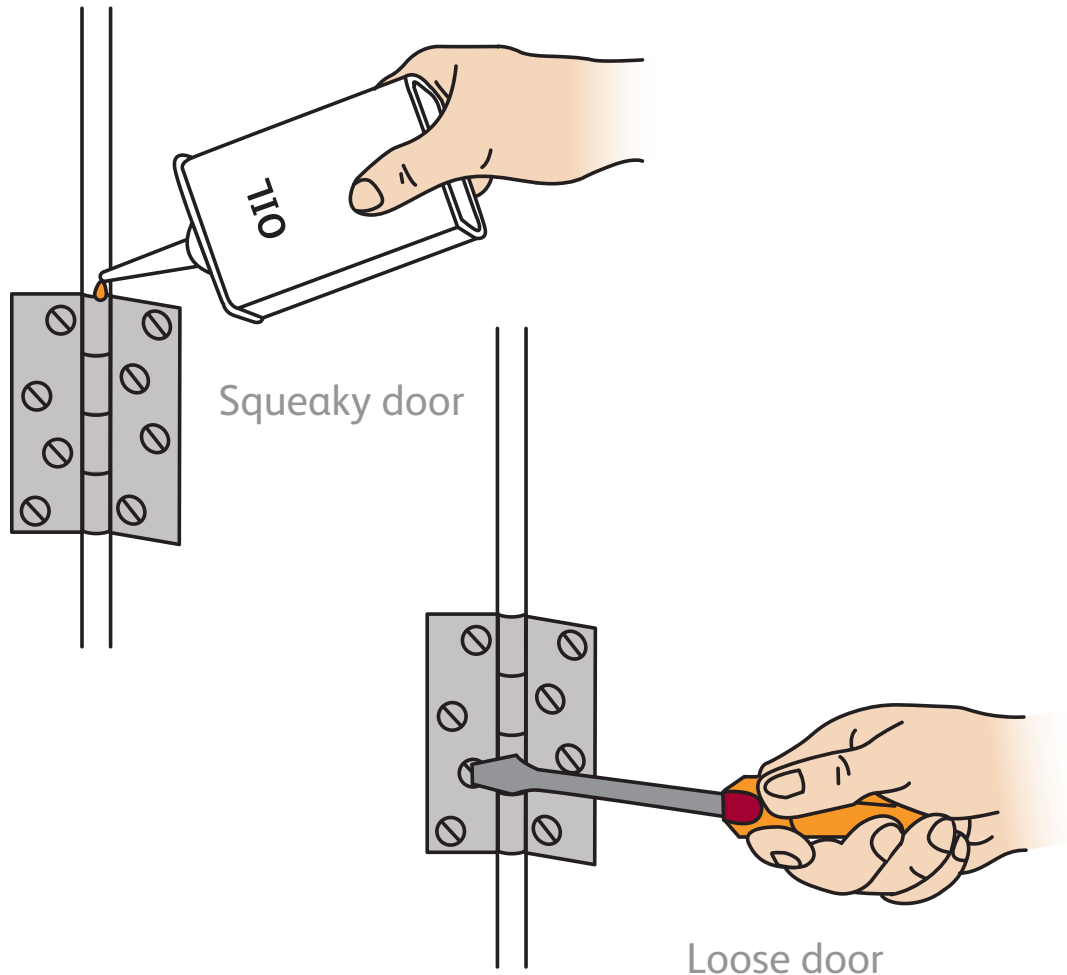

Top Tips

- Try to keep different types and sized screwdrivers in your tool box, so you always have a good fit for the screws. Using the wrong type, such as a Phillips instead of a Pozidrive sized screwdriver can damage the screw head, making it difficult to unscrew.
- Be extra careful with brass, which is soft and easily damaged.
- Remove as much paint as you can from around screws before you begin.
- Always follow the manufacturer's instructions when using oil.



Locks & Latches Guide

How to adjust a sticking door

Difficulty: 

Time needed: 15 to 30 minutes

Tools



Screwdriver

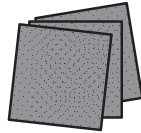

Sandpaper (coarse)

Step-by-Step Instructions

For doors sticking at the top or leading edges

1. Wedge the door open, so you can access the area that is sticking.
2. Rub your sandpaper over the affected area of the door.

For doors sticking at the bottom edge

1. Feed your sandpaper under the door where it is sticking, then move the door back and forth over the sandpaper.

For doors sticking at the hinge edge

1. Use a screwdriver to tighten any loose screws.
2. If this doesn't solve the problem, your hinges might be set too deep into the door or the doorframe. To fix this, wedge the door open and remove the side of one hinge that is too deep. Insert a piece of cardboard where the hinge should go, then screw the hinge back into place. Repeat with other hinges, if necessary.

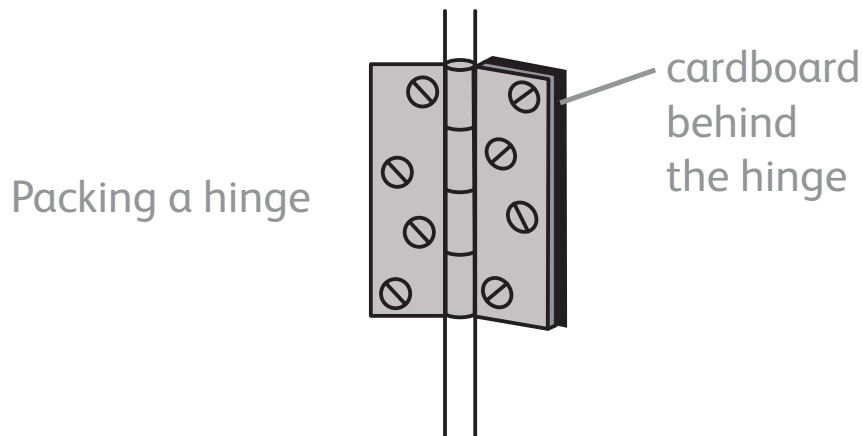

Top Tips

- Don't forget to use a screwdriver that fits the screws. Otherwise, you risk damaging the screw heads.
- If screws get stuck, trying placing the screwdriver into the groove in the screw head, then tapping it with a hammer. Alternatively, try tightening the screw, then unscrewing it.
- If a door is sticking at the bottom edge, check the hinges before you start adjusting the door. You might just need to tighten the screws.



Locks & Latches Guide

How to replace door knobs and handles

Difficulty: ●●○○○

Time needed: 10 to 30 minutes

Tools

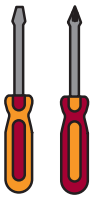

Screwdrivers
(crosshead
and flathead)

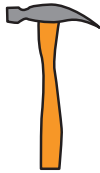

Hammer

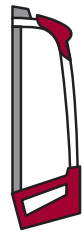

Hack saw

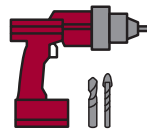

Drill with
2mm bit
(see Top Tips)

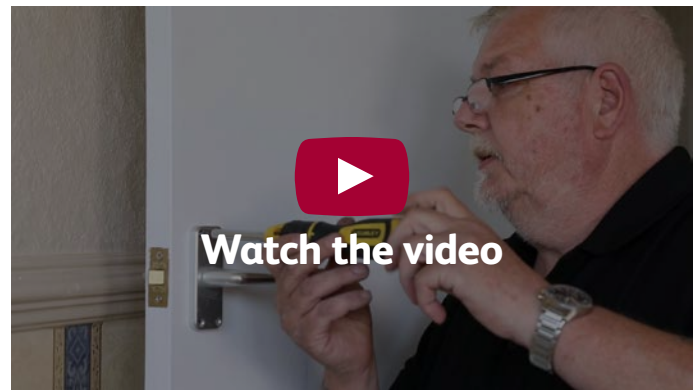

Step-by-Step Instructions

Replacing door handles

1. Use your screwdriver to remove the handles from both sides of the door. If you can't see any screws, you may need to pry off the cover plate first.
2. Check that the spindle of the new handle is the same length as the old one. If not, simply use the old spindle or use a hack saw to cut the new spindle to the right length.
3. Push the new handle's spindle through the hole in the door and slide the handles into place on either side of the door. Before you screw the handles down, check that the door handles work. Once they do, screw them firmly into place.

Replacing door knobs

1. Use a small screwdriver to remove the grub screws from the old door knobs. Then remove both door knobs and the old spindle.
2. Check that the new spindle is the same length as the old one. If not, you could use the old spindle or cut the new spindle to the right length with a hack saw.
3. Push your spindle through the hole in the door and slide the knobs into place on either. Check that the door knobs work, then tighten up the grub screws.

Always follow the instructions of the door handle/knob manufacturer

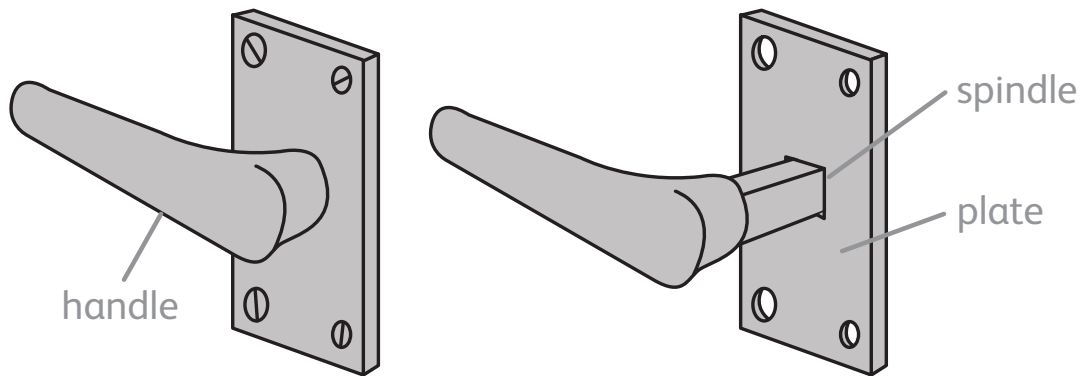

Replacing a set of handles

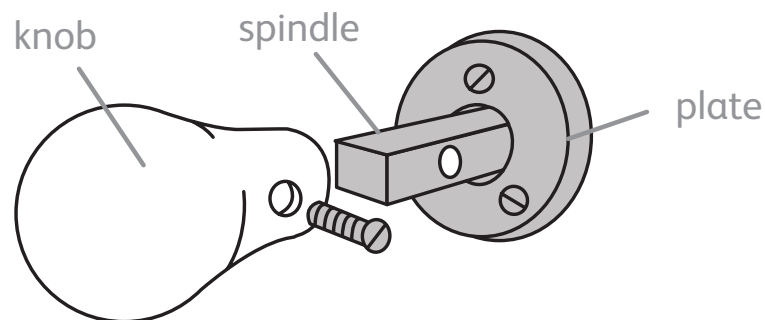

Replacing a set of knobs

Top Tips

- Don't forget to use a screwdriver that fits the screws and to wedge the door open while you work.
- If the new handle's screw holes are in different places to the existing handle, you might want to drill pilot holes for the screws.

Hold the new handle's plate in place, then insert a pencil into each of the screw holes, to mark where the screws will go. Next, put the handle to one side and use a narrow drill bit (e.g. 2mm) to drill holes for the screws. These holes should go roughly halfway through the door.



Locks & Latches Guide

How to replace a mortice latch

Difficulty: (Three red circles, two grey circles)

Time needed: 15 to 30 minutes

Tools

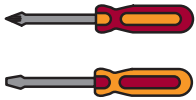

Screwdrivers
(crosshead and flathead)

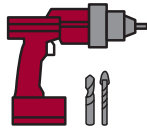

Drill with 2mm bit
(see Top Tips)

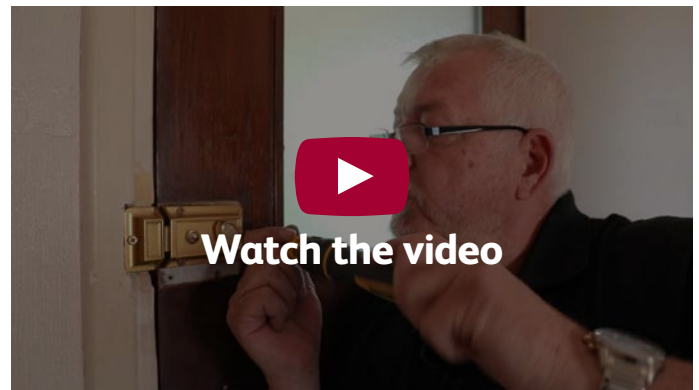

Step-by-Step Instructions

1. Use your screwdriver to remove the handles / knobs from both sides of the old latch, as well as the spindle. (If you can't see any screws, you may need to pry off the cover plate first.)
2. Next, remove the latch plate by undoing its screws. Then insert your screwdriver into the hole where the spindle would go and push the latch mechanism out of the door.
3. Insert the new latch into the door and screw on the new latch plate. You may need to prepare pilot holes for the screws if they don't line up with the existing holes (see Top Tips).
4. Push the spindle into place and re-attach the handles / knobs.
5. Check that the mechanism works before screwing everything back together again.

Always follow the instructions of the mortice latch manufacturer

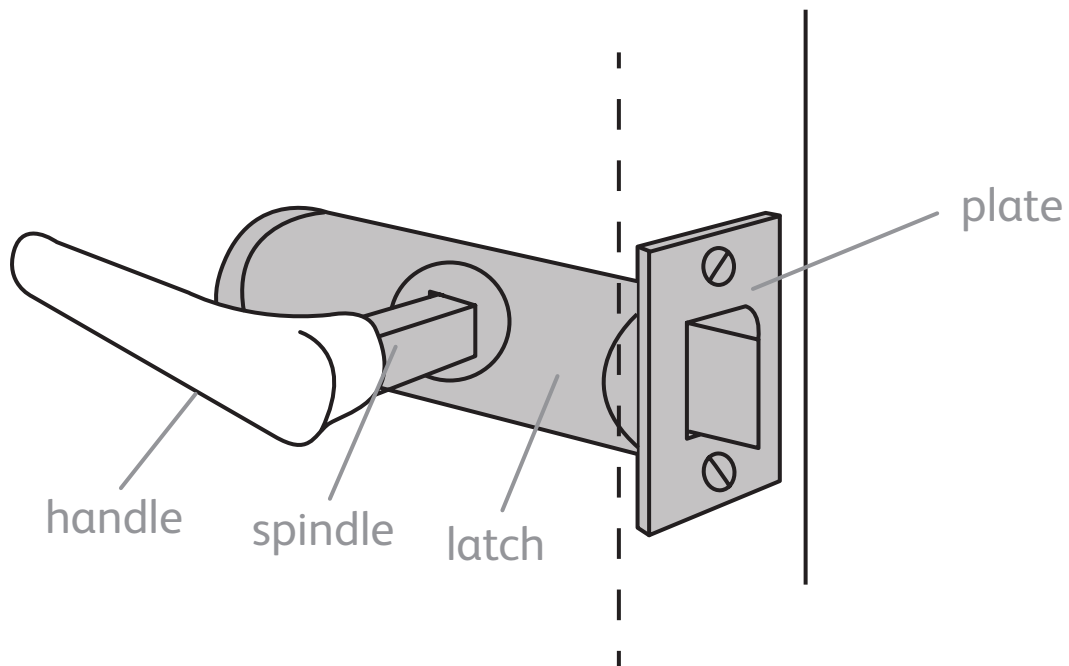

Replacing a mortice latch

Top Tips

- Don't forget to use a screwdriver that fits the screws and to wedge the door open while you work.
- If the screw holes in the new latch plate don't line up with the existing holes in your door,

you might want to drill pilot holes for the screws. Hold the new latch plate in place, then insert a pencil into each of the screw holes, to mark where the screws will go. Next, put the latch plate to one side and use a narrow drill bit (e.g. 2mm) to drill holes for the screws.



Locks & Latches Guide

How to fit a door chain

Difficulty:

Time needed: 15 minutes

Tools



Door Chain

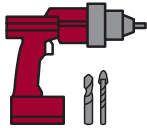

Drill and bits



Screwdriver
(crosshead)



Pencil

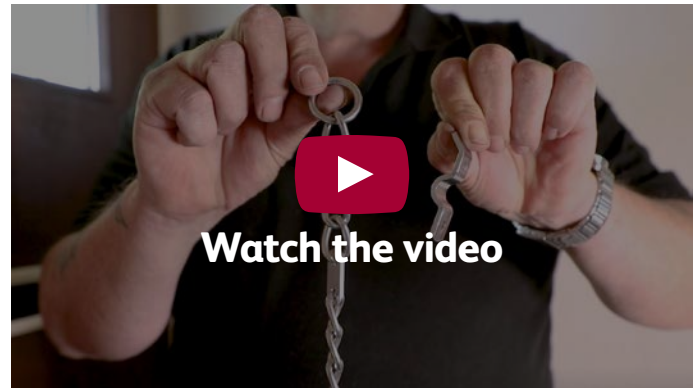

Step-by-Step Instructions

1. Position the chain anchor on the door, so that it is flush with the edge. Mark screw holes with a pencil (Fig 1).
2. Drill pilot holes into the door, using a 2mm bit. Make sure that the drill bit is not longer than the screws or the width of the door.
3. Use a screwdriver to screw the chain anchor into place.
4. Position the chain hook on the door frame, so that it lines up with the chain anchor. Make sure the hook is on the top before marking screw holes with a pencil (Fig 2).
5. As before, drill pilot holes into the door frame.
6. Attach one end of the chain to the chain hook, then screw the chain hook into the door frame.

Always follow the instructions of the door chain manufacturer

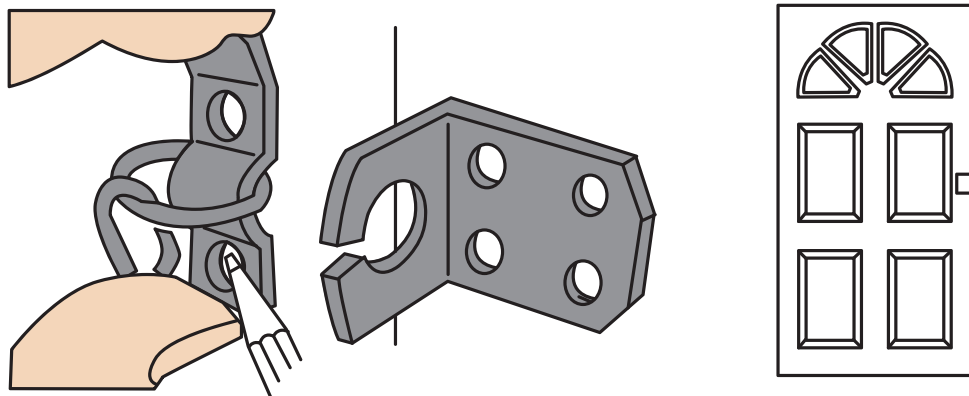
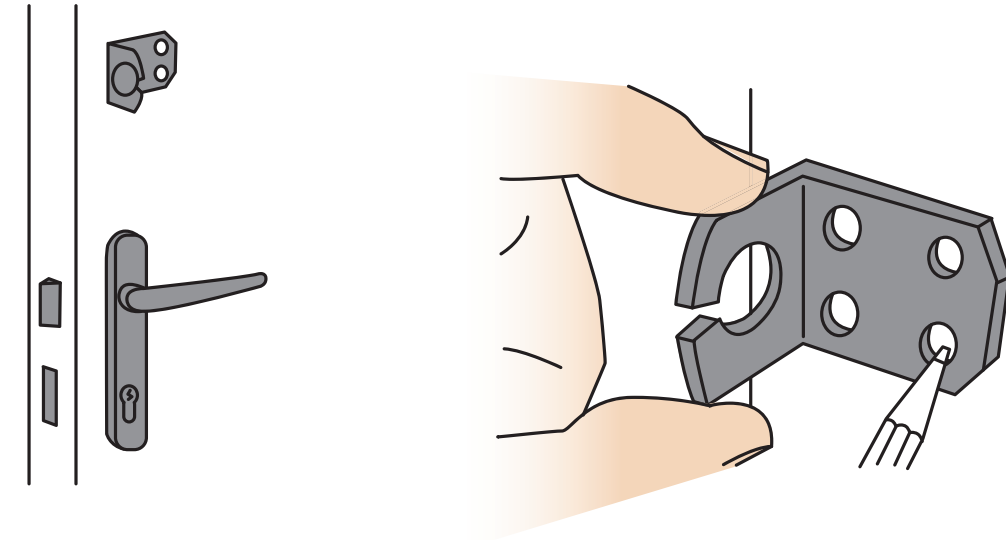

(Fig 1)

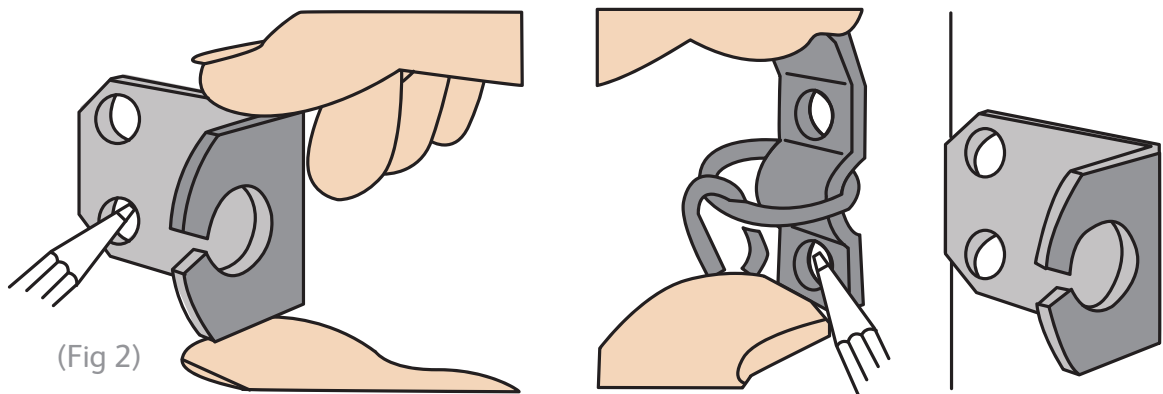

(Fig 2)



Locks & Latches Guide

How to replace a cylinder lock

Difficulty:  

Time needed: 30 to 45 minutes

Tools



Screwdriver (crosshead)



Tape measure



Step-by-Step Instructions

1. Certain cylinders due to their premium security features may require you to remove your door handle. Check before you start the task. To remove the handle open the door and remove the fixing screws and then remove both sides of the handle. (Fig 1)
2. Next, remove the cylinder fixing screw, which is level with the bottom of your existing cylinder. (Fig 2)
3. Then insert the key in the cylinder and turn to remove. Sometimes they can be a bit stubborn to get out so twist the key left and right to align the cam with the cylinder. (Fig 3)
4. You will need to measure the size of the existing cylinder by measuring the length of each half to the center of the cam. This will give you two measurements, it is important to know which measurement is for the external side and which for the internal side as the external side has the protection against attack. (Fig 4)
5. Once you've purchased your new euro profile cylinder insert the key and align the cam with the centre of the cylinder then place it into the lock. Again you may need to twist the key slightly to ensure the cylinder slots into the lock.
6. It's important to remember that the cylinder has an external side and an internal side so make sure that these are the correct way round.
7. Next replace the cylinder screw and screw tightly to secure your new cylinder in place. Lastly replace both sides of the handle and fix back in place. Then test the operation of the handle together with the lock to check it works correctly.

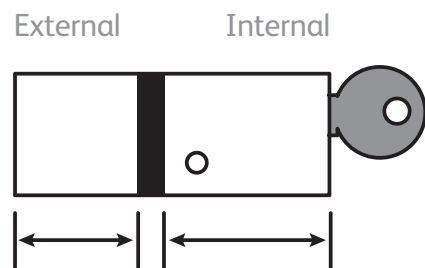
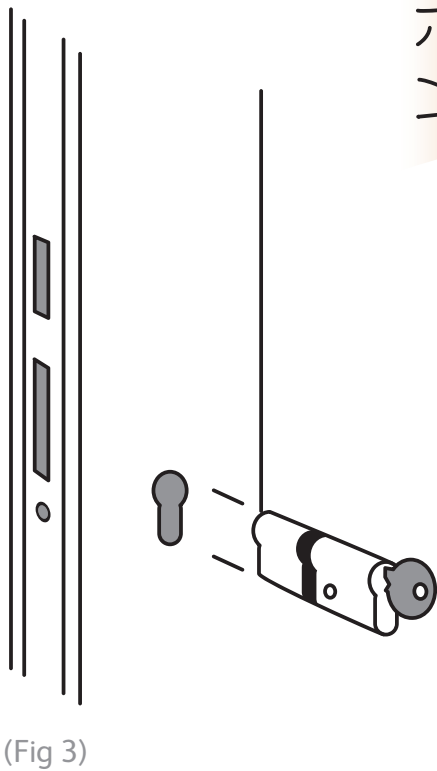

Guide to Central Heating

How to set a digital programmer	44
How to set a time-clock programmer	46
How to control heating temperature	48
How to use a storage heater	50
How to use a panel heater	52
How to look after your heaters	54
How to use heat effectively	55
How to thaw a condensate pipe	56
Freeing up a Thermostatic Radiator Valve Pin	57





Central Heating Guide

How to set a digital programmer

Difficulty: 

Time needed: 5 to 10 minutes

Step-by-Step Instructions

Although there are many different types of digital heating programmers, these instructions should work in most cases.

1. First, make sure the time is right on the programmer. If not, switch to clock mode and set the time using the forward (+) and backward (-) buttons.
2. Think about when you want to use your heating. Switch to heating mode and set times for each on and off setting in the same way you set the time.
3. With some programmers, you will be able to separate programmes for different days of the week. Simply set each day, based on the times you expect to be up and about in your home.
4. Most digital programmers have an auto mode, in which the programmer will follow the instructions you have just set. Switch the programmer to this setting when you are finished.
5. If these basic instructions don't work, and you can't find the manufacturer's instructions, you may be able to download them from the Internet. Note down the make and model of your programmer (or boiler, if the programmer is part of the boiler itself) and type it into your search engine (Google, Bing, Ask, etc.) with the word 'manual'.

Top Tips

- Most digital programmers have some sort of manual over-ride.
- This might be a manual mode or an advance button. If there is a manual mode, you will need to put the programmer back into auto mode to resume the programme. With an advance button, the programmer skips ahead to the next on / off time, then follows the programme as usual, meaning you don't have to remember to reset your programmer.
- Some programmers allow more complex programmes than others. You might be able to set multiple on / off times throughout the day. You might also be able to set different programmes for different days of the week.
- Remember, you only need the heating to be on when you are up and about in your home. During warm and even mild months, heating your home while you are at work or in bed will usually be a waste of money.



Central Heating Guide

How to set a time-clock programmer

Saving energy and money

Difficulty: 

Time needed: 5 to 10 minutes

Step-by-Step Instructions

Although there are many different time-clock programmers, they come in main varieties: those with pins and those with arrows. These instructions should work in most cases:

1. First, make sure the time is right on the programmer. If not, turn the dial until the correct time is showing.
2. Set on/off times as follows, based on the type of dial you have:

Type of dial	Action
Pins	Push pins in when you want the heating to be on; pull the rest of the pins out.
Arrows	Wherever you put the 'on' and 'off' arrows, the heating will switch on and off. Make sure the arrows are in the right sequence (i.e. A, B, C, D).

3. There will usually be switches that let you set the programme to apply to heating, hot water or both.
4. Switch the programmer to its auto setting when you are finished.
5. Using the manual, on or off settings will override your instructions. Remember to put the programmer back into auto when you want it to go back to following your presets.
6. If these basic instructions don't work, and you can't find the manufacturer's instructions, you may be able to download them from the Internet. Note down the make and model of your programmer (or boiler, if it the programmer is part of the boiler itself) and type it into your search engine (Google, Bing, Ask, etc.) with the word 'manual'.
7. Ask the service engineer at your next gas safety (LGSR) inspection

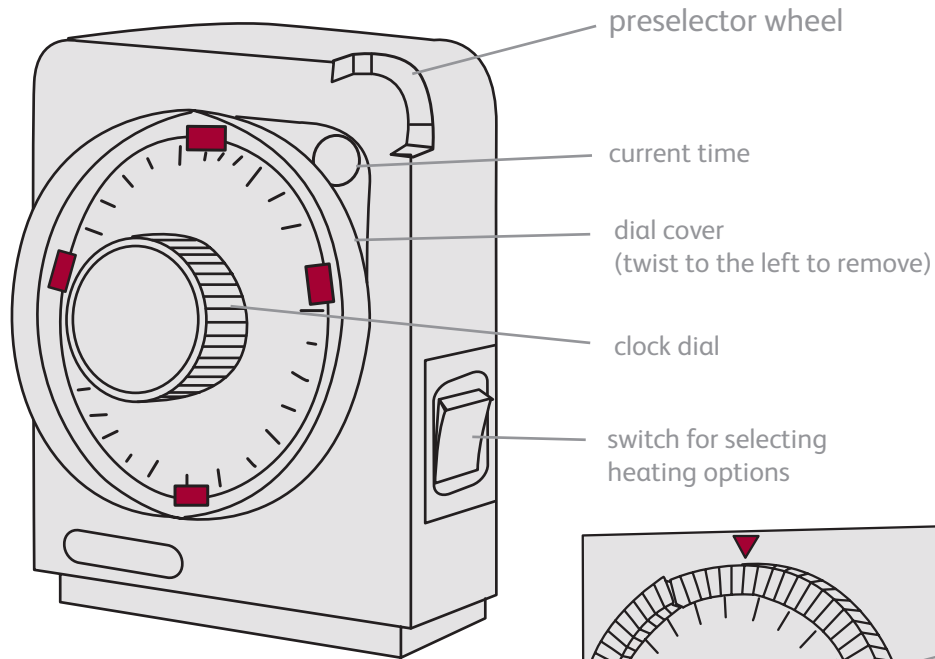

Programmer with once/twice options

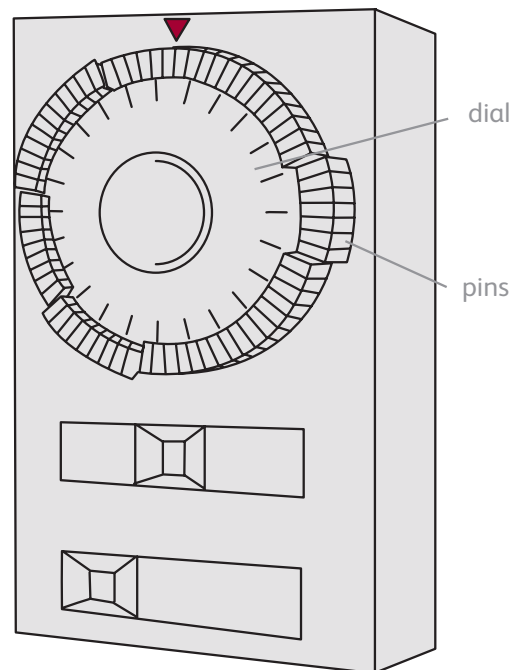

Programmer with pins

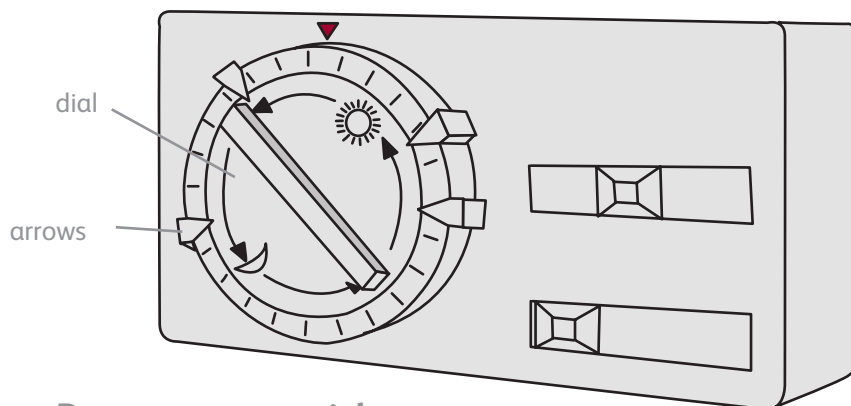

Programmer with arrows



Central Heating Guide

How to control heating temperature

Saving energy and money

Difficulty: 

Time needed: 5 to 15 minutes

Step-by-Step Instructions

Controlling heating temperature

1. Your room thermostat controls the baseline temperature for every room in your home. Simply turn the dial the desired temperature (18 to 22 degrees).
2. In individual rooms, you can turn the heating down by adjusting the radiator settings in those rooms. A gatevalve simply turns the radiator 'on' or 'off'; a thermostatic valve gives you more control of the temperature as it automatically turns the radiator on and off to maintain your desired temperature in the room.

Controlling hot water temperature

1. Most boilers have an internal thermostat control that sets the maximum temperature for the hot water system to 62 degrees.
2. If you have a manual control on your boiler, you may lower the hot water temperature to suit your own preferences. Lowering the temperature of your hot water by even a couple of degrees will save energy (and money).

Top Tips

- If you have one, a room thermostat controls the temperature of your entire home. It monitors the ambient temperature in the room in which it is placed. Whenever it is colder than the setting you have selected, the thermostat will turn on your heating. When it is warmer than your desired temperature, the thermostat turns your heating off again.
- Some rooms need more heat than others. You can use radiator valves to isolate rooms from the heating system (e.g. spare bedrooms, rooms with fireplace or rooms that catch a lot of natural sunlight).
- For most people, anything between 18 and 22 degrees is a comfortable room temperature.
- Ask the service engineer at your next gas safety (LGSR) inspection

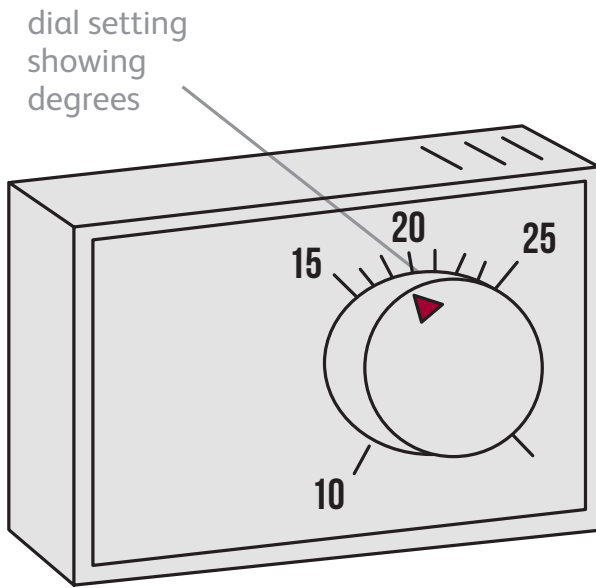

Room thermostat

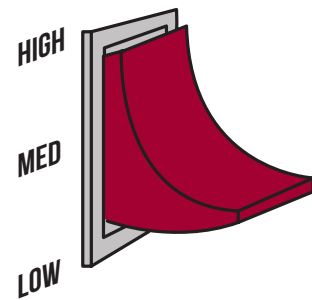
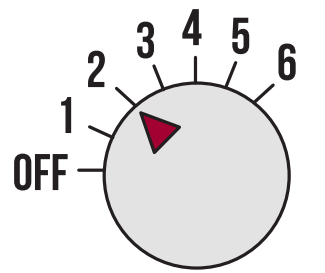

Boiler thermostats

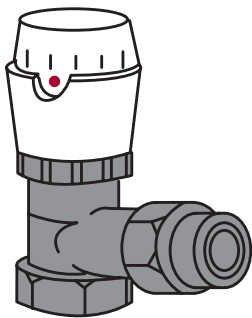

Thermostatic valve

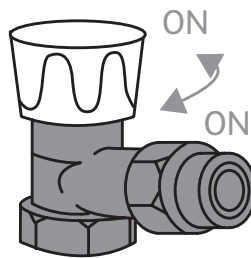

gate valve

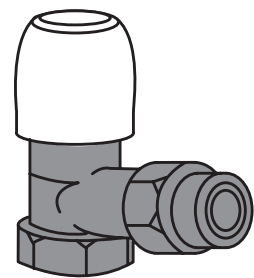

lockshield valve
(do not turn)

Radiator valves



Central Heating Guide

How to use a storage heater

Difficulty: 

Time needed: 5 minutes

What are Storage Heaters?

- Storage heaters can be a cost effective way to heat rooms, as they only consume electricity at night (when it is cheaper). You can also set the heaters in each room individually, so you aren't wasting energy heating a room you barely use.
- Most storage heaters have a 'boost' setting that lets you conserve heat until you want it most (i.e. when you're in the room).
- Heat is emitted across the entire surface of the heater, so you might need a guard to stop young children from burning themselves.
- If your storage heater has a boost function, extra heat will come from a grill on the top of the heater. To conserve energy, only open the grill when you want the extra heat and close it before you go to bed.
- When you set a heater, remember that it takes 24 hours for the heater to store the heat. Don't expect anything to change until the day after you set the heater.
- To get the most out of your storage heater, try to get into the habit of checking the weather forecast for the coming day and adjusting your input accordingly.
- Finally, if you are going away or you aren't going to use a particular room for a while, turn the heater off at the wall.

Step-by-Step Instructions

You set a storage heater using two controls: output and input. The output controls how much heat is emitted by your heater. Set at '1', the heater will emit a constant heat, gradually cooling throughout the day. Set at '6' the heater will release as much heat as it can, so don't set the output this high until you really need it.

The input controls how hot the heater will get, and therefore how much energy the heater will consume overnight. This will be a numbered dial, with '1' being cool and '6' being very hot indeed.

1. To start with, set the input to '4'. If this is not hot enough the next day, you can raise the input to '5' or '6'. Alternatively, if it is too hot, you can
2. lower the input a notch at a time until it feels right.
2. If you are going to be in your home for most of the day, leave the output as low as possible. This will slowly release heat throughout the day. If you are going out, leave the output on its lowest setting while you're out, then turn it up when you come home. Generally speaking, the longer you intend to be at home, the lower the output should be. It may take some trial and error before you get the hang of this.
3. Finally, if you turn the output up to get a heat boost in the afternoon or evening, don't forget to turn it back down before you go to bed.

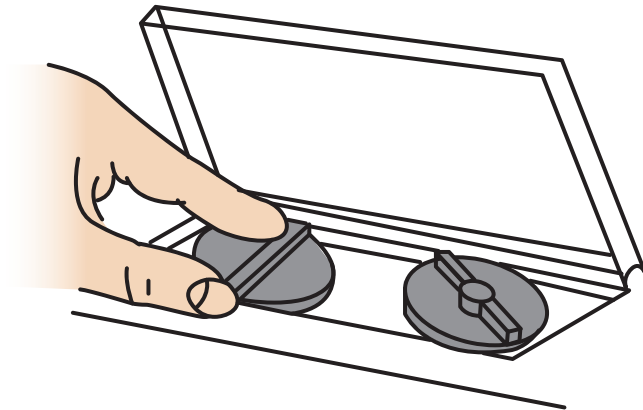

Storage heater

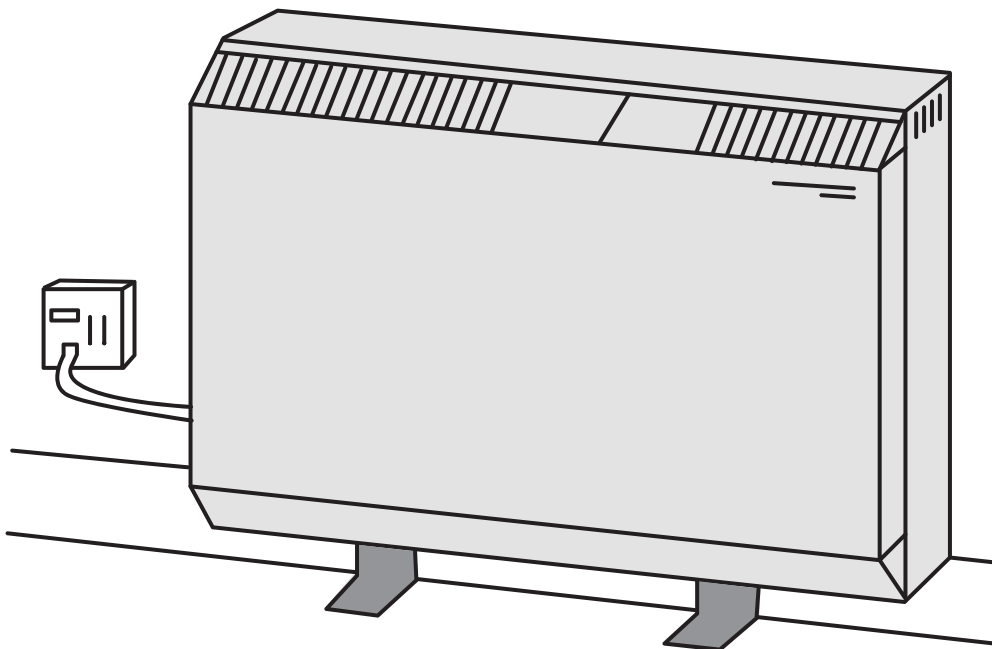

Note:

- Follow manufacturers instructions



Central Heating Guide

How to use a panel heater

Difficulty: 

Time needed: 1 minute

What are panel heaters?

- Don't confuse panel heaters with storage heaters. Although they often look similar, panel heaters consume electricity as you use them (i.e. at premium rates), so you are unlikely to save money with them.
- The chief advantages of a panel heater are maintenance and reliability. They require almost no maintenance and are very easily replaced. Additionally, if your combi-boiler breaks down, you lose heat and hot water throughout your home. If a panel heater breaks down, you still have heat in your other rooms.

Step-by-Step Instructions

1. You can set a panel heater's temperature using a dial. This is fairly responsive, so you can adjust the temperature as you see fit. Many panel heaters have 'full' and 'half' heat settings, giving you extra control over the temperature (and how much electricity you use).
2. When you enter the room, switch on the panel heater.
3. When you leave, switch it off again. It's that simple!
4. Some models come with a timer, so you can set your panel heater in the same way you might set a central heating system. This is especially helpful if you are a bit forgetful, as panel heaters use a lot of electricity if left on for long periods.

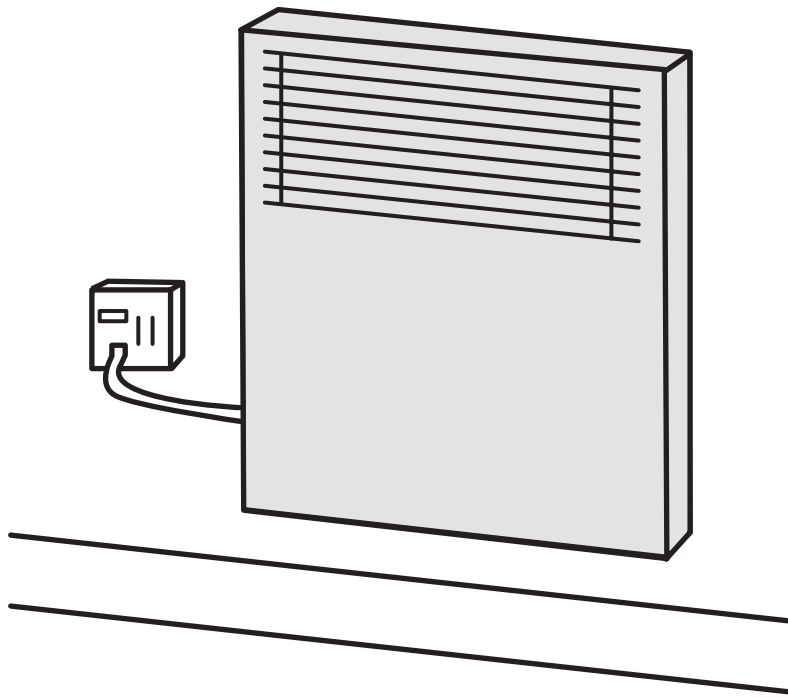

Panel heater



Central Heating Guide

How to look after your heaters

Difficulty: 

Top Tips

- **Don't put anything on or near the heater.** This is for two main reasons. Firstly, the entire surface of the heater gets hot. It is very easy to burn yourself and you can burn or melt materials that get too close for too long. Secondly, the heater needs space to heat a room properly.
- **Get a guard.** The only exception to the above rule is a protective guard. These can be fitted around the heater, so that people (especially children) don't accidentally burn themselves.
- **Ventilation.** Like any other form of heating, ventilation is important to keep the air in the room fresh and to reduce condensation.
- **Keep it clean.** To keep the grill free of dust and day-to-day grime, clean the heater regularly. Don't bother with polish - all you need is a soft, dry cloth. Just make sure the heater isn't on when you clean it.
- **Don't let the heaters get wet.** Storage and panel heaters are both electrical appliances. If they get wet they could short or cause electric shocks, so keep all liquids away from them.
- **Don't move the heater.** If you want to move or fit a heater, contact Royal Borough of Kingston.

How to use heat effectively

Difficulty: 

Step-by-Step Instructions

1. Stop cold air coming into your home. There is a section on fitting draught proofing later in this booklet, but heavy curtains will also help. Keeping internal doors closed will also make a big difference, especially when an external door is open.
2. Keep heat in your home as long as possible. This doesn't just mean double-glazing or loft and

cavity wall insulation. Keeping radiators free of obstructions (such as clothes horses full of wet clothes) will help heat circulate. Good underlay beneath your carpets will limit the heat leaving through the floorboards, while lagging around pipes will lock the heat in where it belongs.

Top Tips

- In cold weather, it is best to maintain a low level of heat in your home throughout the day.
- Don't forget to ventilate your home. Open windows whenever you can, to keep the air in your home fresh and to minimise condensation.
- Teenagers have a habit of standing at the front door when friends call. Get them to come in and shut the door as this wastes enormous amounts of energy to reheat the room/hallway.



Central Heating Guide

How to thaw a condensate pipe

Difficulty: 

Top Tips

- **Use hot water – not boiling.**
Heat the water by a kettle or a microwave and allow to cool from boiling before pouring over the end of the pipe where it is frozen using a suitable container like a jug or watering can.
- **Use a hot water bottle.**
Hold a hot water bottle or heat wrap around the condensate pipe.
- **Boiler reset.**
Once the pipe has thawed you should re-set your boiler by holding in the re-set button for 10 seconds and wait for the boiler to re-fire.

Warning:

- Never attempt to thaw a condensate pipe above waist level, or disconnect the condensate pipe in order to do so.
- Never attempt to access the condensate pipe or any other pipe work within the boiler.
- Beware of ice on the ground that will form from the water you have poured.

Freeing up a Thermostatic Radiator Valve Pin

Difficulty: ●●○○○

Tools



Pliers



Adjustable grips

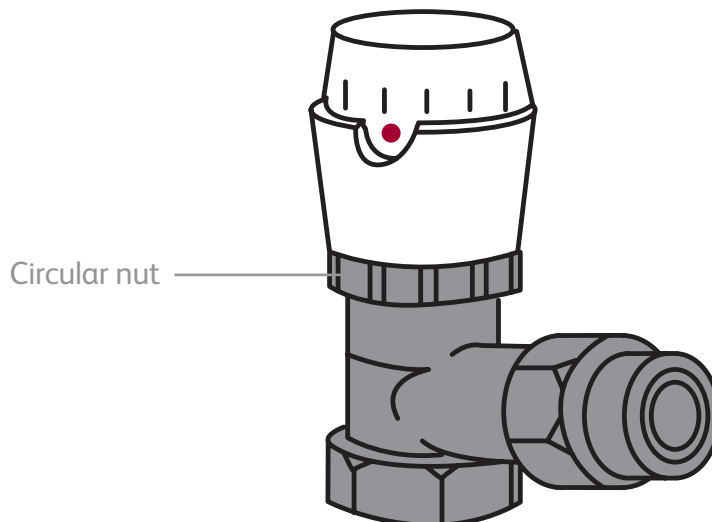

Step-by-Step Instructions

1. With a pair of Adjustable Grips placed around the Circular Nut, located just below the White Plastic Valve Head, turn anti-clockwise to loosen the Nut.
2. Continue to loosen the Nut until the White Plastic Valve Head can be lifted clear of the Chrome Valve.
3. With a pair of Pliers, gently tap down on the Small Pin located in the centre of the Main Valve Body a few times. This will free the Pin from it's closed position.
4. Apply a small amount of Vaseline around the Pin. This will ensure the Pin will remain free & flexible during future use.
5. Place the White Plastic Valve Head over the Chrome Valve & begin to hand tighten the Circular Nut on the Chrome Valve by turning Clock-Wise until you can turn no more.
6. With a pair of Adjustable Grips placed around the Circular Nut, located just below the White Plastic Valve Head, give a final Clock-Wise turn to fully tighten the Nut.

Guide to Draught Proofing

How to fit a brush strip	60
How to fit draught seals	62





Draught Proofing Guide

How to fit a brush strip

Difficulty: ●●○○○

Time needed: 15 to 20 minutes

Tools



Brush strip



Hack saw



Pliers
(with cutting tool)



Screwdriver
and screws
(if necessary)



Tape measure and
pencil

Step-by-Step Instructions

1. Close the door and measure its width.
2. Slide the brush insert from its metal carrier strip, as the two components need to be cut to length separately.
3. Mark the width of the door on the metal carrier strip and cut this to length with a hack saw.
4. Mark the same distance on the brush insert, but use the cutting tool on your pliers to cut it. This will stop the bristles from falling out from where you've cut.
5. Lightly bend the brush insert and then slide it back into the metal carrier strip.
6. **If the strip is self-adhesive**, simply peel back a little of the backing from one of the strip and attach it to the base of your door. Remove a little backing at a time and firmly press the brush strip onto the door, making sure the bristles brush against the floor (or carpet). **If the strip has screw holes**, position it against the base of the door, making sure the bristles brush against the floor. If you need to drill pilot holes for the screws (**see Top Tips**), mark each screw hole with a pencil, so you know where to drill. If you are drilling pilot holes, put the brush strip to one side, so you don't damage it with your drill. Then re-position the strip and screw it into place.

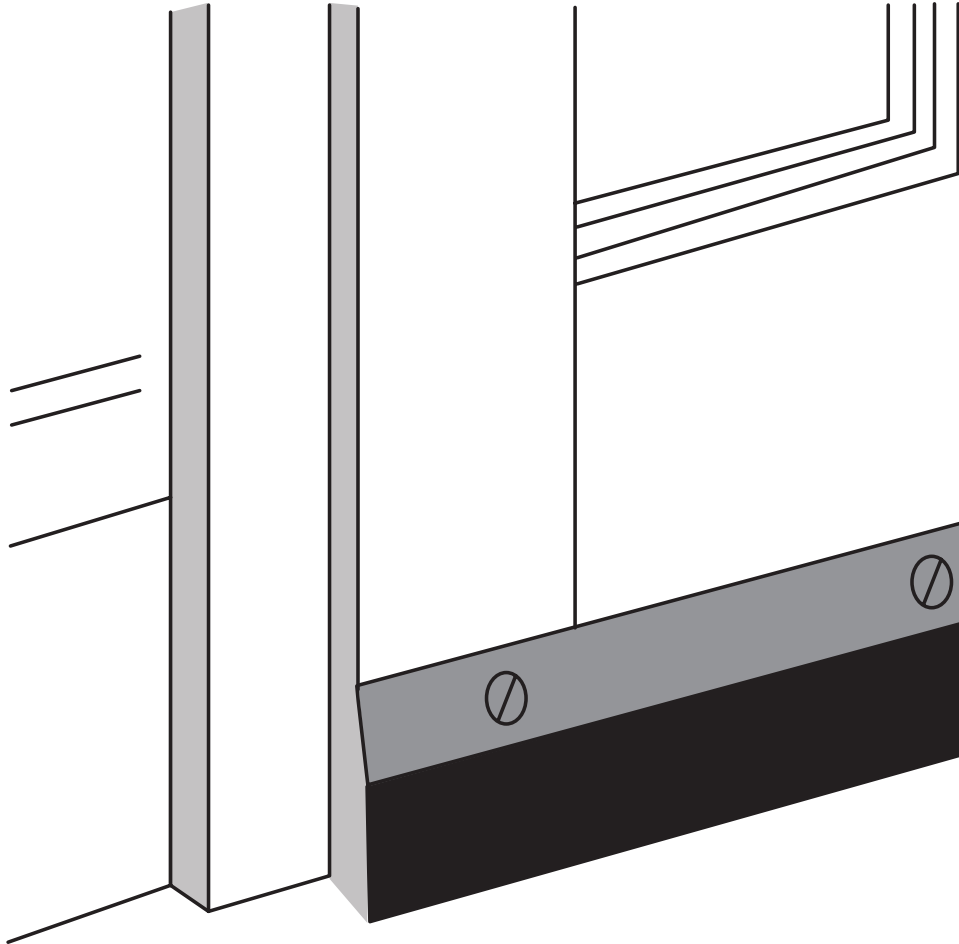

Top Tips

- If you are not careful while fitting your brush strip, you could shed a lot of bristles. Make sure you cut it separately from the metal carrier strip, use pliers (not a hack saw) and bend it slightly before re-inserting it into the carrier strip.
- Chances are there won't be existing screw holes at the base of your door, so pilot holes might be a good idea. Use a narrow drill bit (i.e. 2mm) to drill roughly halfway through the door. This will give your new screws something to grip, which will make screwing them in a lot easier.
- If you are screwing the brush strip to your door, don't tighten the screws right away. Screw them all in loosely, so you can adjust the position of the strip. Make sure you push the bristles against the floor before tightening the screws.



Draught Proofing Guide

How to fit draught seals

Difficulty: 

Time needed: 10 to 20 minutes

Tools



Draught seals



Scissors



Tape measure

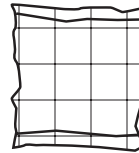

Damp cloth

Step-by-Step Instructions

Draught seals can be fitted to door frames, window frames and loft hatches, but the method is more or less the same in each case.

1. If you are sealing a door, wedge it open. For loft hatches and window frames, just make sure they can't close on you while you work.
2. Wipe the frame with a damp cloth so that you are attaching the seals to a clean surface. Allow the frame to dry before you start sticking the seal to it.
3. Measure the height and width of the frame and cut the draught seal to those lengths. Where two strips meet at a corner, use scissors to make a 45 degree cut so that the strips fit together.
4. To attach the seal to the frame, remove a little of the backing and press the seal to the frame. Slowly work your way around the frame until you are finished.

Top Tips

- Draught seals (also called weatherstrips) come in different shapes and sizes (and colours). Make sure you measure the gap you are sealing before you buy your draught seals.

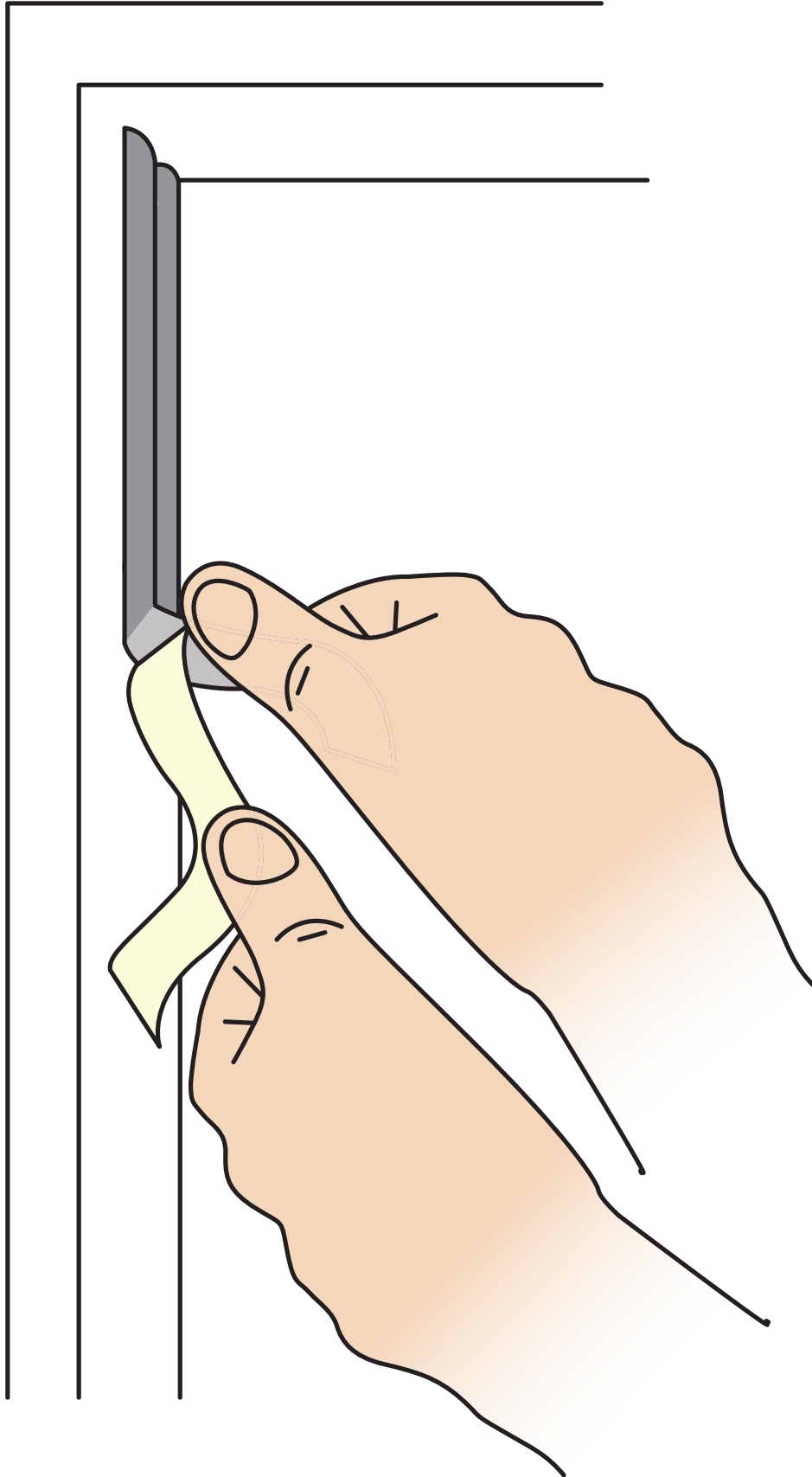

Guide to Decorating

How to fix things to walls	66
How to prepare a room for decorating	68
How to strip wallpaper	70
How to paint	72
Mastic baths, basins and sinks	74





Decorating Guide

How to fix things to walls

Difficulty: 

Time needed: 10 minutes

Tools

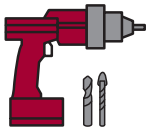

Drill and bit



Screwdriver



Wall plugs

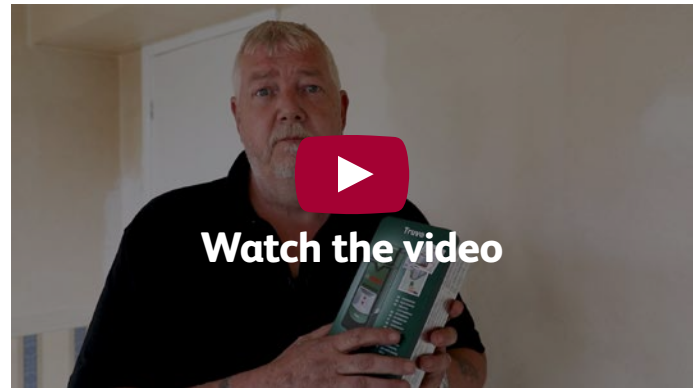

Warning:

You need to know where pipes and cables are located within your walls before drilling. This can be done with a detector and being mindful of where outlets are e.g. plug sockets. This is for your safety and to avoid any tenant recharge for damage to wiring and plumbing.

Step-by-Step Instructions

Screwing into brick or concrete walls

1. Make sure your screw, wall plug and drill bit are all a good size match.
2. Make a hole for the wall plug by drilling into the wall. You should drill roughly 1cm deeper into the wall than the length of the plug.
3. Insert your plug into the wall, it should sit in the hole no more than a 1/3 of its length. Then tap the remaining plug into the wall with a hammer so that it is flush with the surface. You can then screw your screw into the wall plug.

Screwing into hollow plasterboard or hollow doors

1. Make sure your screw, wall plug and drill bit are all a good size match. When screwing into a hollow, you can use an expanding plug or ideally a corkscrew type plug such as a "Redi drive".
2. Make a hole for the plug by drilling into the plasterboard or door. Be very careful, as you could easily drill through the opposite side of the hollow.
3. Insert your expanding plug through the hole. This will expand as you screw in your screw, to hold the screw in position. If using a corkscrew type plug, use a crosshead screwdriver to screw the plug into the hole, ready to accept the screw.

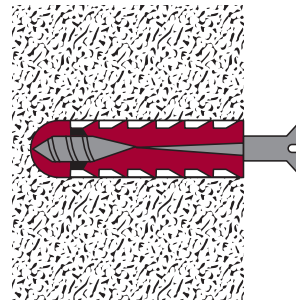
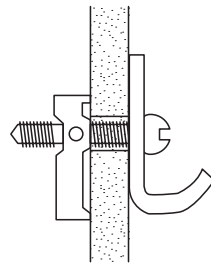
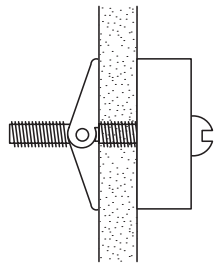

Solid wall fixing

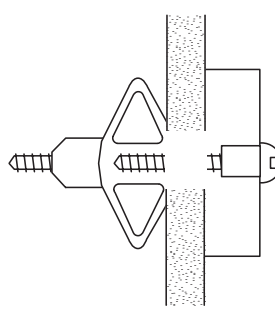
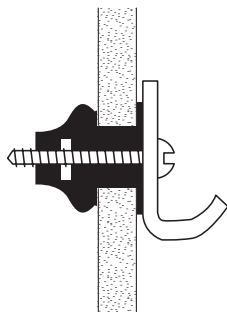

wood bit

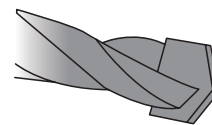

masonry bit

Hollow board fixings

Drill bits

Top Tips

- Drill bits come in lots of shapes and sizes. First, make sure you are using the right bit for the material you are drilling into. Next, check that your bit is a good size match for the screws you are using, as follows:

Screw size	Bit size
4 to 6	8
7 to 9	10
10 to 12	14
13 to 15	16

- Make sure your drill bits are sharp.
- Be aware of water pipes and electrical cables wherever you are drilling. Be mindful of sockets and light switches, as electrical cables will usually run vertically or horizontally to them. Use a miniature metal detectors from a DIY store to be safe.
- Make sure the screw only just fits into the wall plug and the drill bit is slightly smaller than the wall plug.
- Wall Plugs come in different colours, the most common being red or brown. The smaller red plug should be drilled with a 5.5mm masonry bit. The brown, with a 6.5mm masonry bit.



Decorating Guide

How to prepare a room for decorating

Difficulty: 

Time needed: Varies

Tools

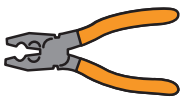

Pliers

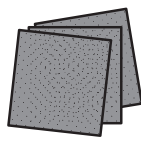

Sandpaper



Cloth and
sugar soap



Masking tape



Filler



Filling Knife

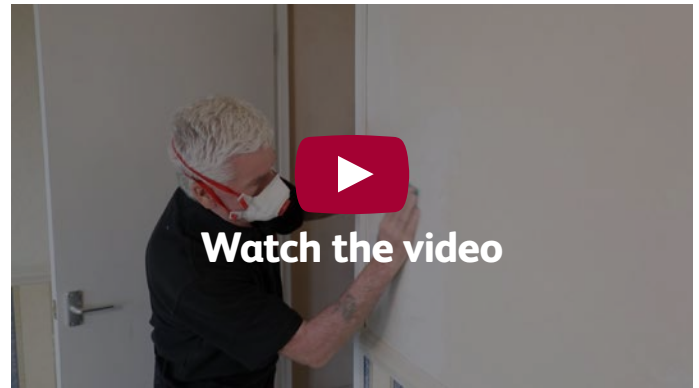

Watch the video

Warning:

Make sure you have adequately protected carpets, furniture and woodwork before you start

Step-by-Step Instructions

1. Check the walls for any nails or hooks and remove these with your pliers. Then, fill in the holes that are left with some filler.
2. Use sandpaper on the plaster or wood you will be decorating. Whatever you are putting on your walls, you need an even surface. Using sandpaper also gives surfaces a little roughness that will help paint stick. If you can't get an even finish, you may need backing paper.
3. If you are painting, stick a strip of masking tape to any window panes, fixtures or floor coverings that run adjacent to the area you plan to paint. This will help prevent paint going where it shouldn't.
4. If you can safely remove a fixture, such as handles or switches and sockets, do so. Otherwise, stick masking tape around the edges.
5. Finally, wipe down the area you are decorating with warm water and sugar soap, to get rid of any dust or dirt. These could ruin the finish, so always work on a clean surface. Once everything is dry, you're ready to decorate.

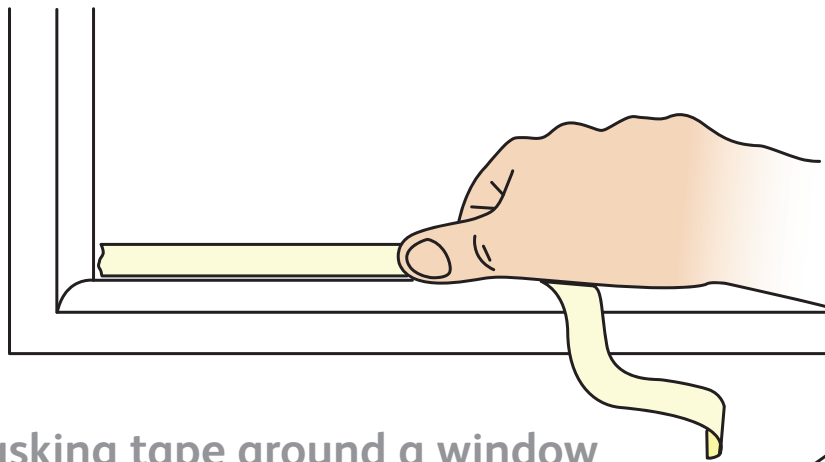

Masking tape around a window

Warning:

Never sand a surface if you believe it might be Asbestos

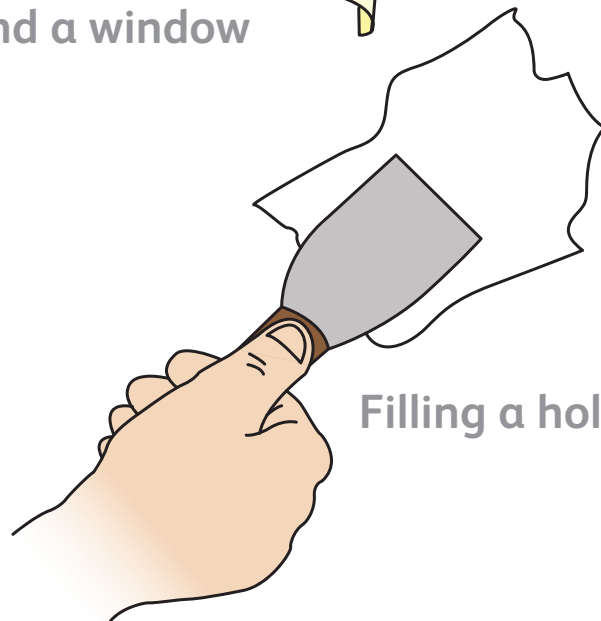

Filling a hole

Top Tips

- Make sure the room is clean before you start. That means washing and dusting.
- If you can't remove furniture from the room, cover it with some old bedding or curtains. The same goes for carpets.
- Open as many windows as you can, so paint fumes don't build up in the room.
- If you don't have overalls, wear old clothes that you don't mind splashing painting onto. Also, wearing rubber gloves will help protect the skin on your hands, as paint can sometimes be hard to remove.
- Keep children and pets away from the room until you are finished and everything has dried.
- Putting up wallpaper isn't the most difficult DIY job, but it takes preparation and practice. You'll need some kit and some know-how, so make sure you do some reading or watch some wallpapering tutorials on YouTube before you begin.



Decorating Guide

How to strip wallpaper

Difficulty: 

Time needed: Varies

Tools



Sharp knife

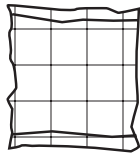

Cloth



Water

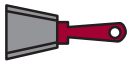

Wall scraper



Steamer



Stepladders



Warning:

Make sure you have adequately protected carpets, furniture and woodwork before you start

Step-by-Step Instructions

Strip as much paper as you can by hand, then use a sharp knife to cut criss-crossing lines (roughly 2cm apart) into the remaining paper.

Warm water and wall scraper method

1. Use your cloth to wipe warm water over one strip of paper. Give the water some time to soak in, then get scraping!
2. If the paper is still too dry, just wipe it down with warm water again. Let the water soak in, then scrape.

Steamer method

Although there are many different models of wallpaper steamer, they all work in more or less the same way. You should always read and follow the manufacturer's instructions, but these general guidelines will help with all steamers:

1. Wait until steam is coming from the plate before you start using the steamer.
2. Starting at the top, hold the plate against the paper for no more than 10 seconds. You should now be able to remove the paper quite easily, either by hand or using a scraper.

Whichever method you have used, your walls will probably feel slimy from all the old wallpaper paste. This will wash off with some warm water and washing up liquid.

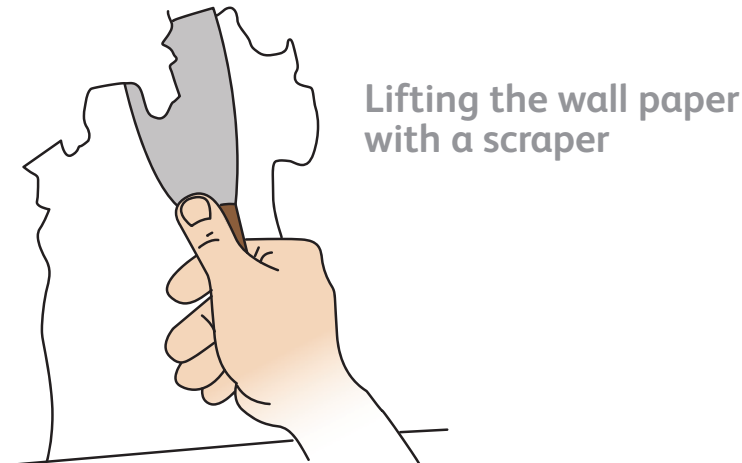
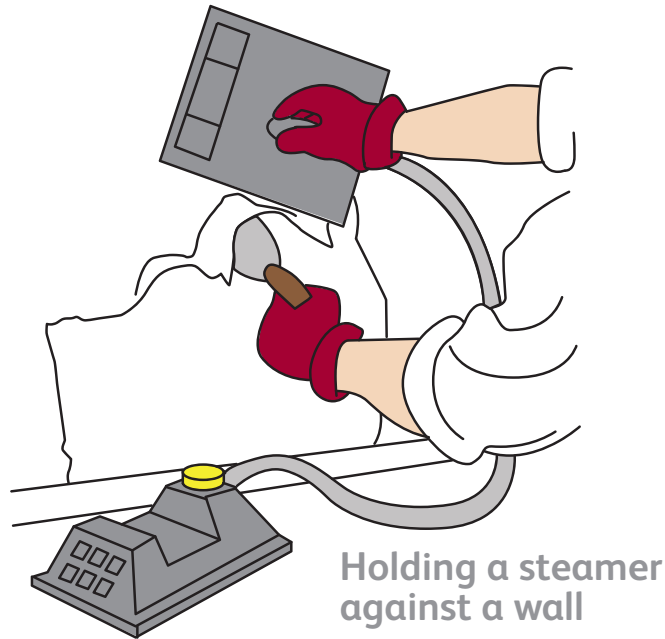

Top Tips

- Think about what you want to do to the room before you strip the paper. If you only want to paint the room and the wallpaper isn't too glossy or textured, it might make good backing paper.
- If you do need to strip the walls, try removing some of the paper by hand first. This will help you decide whether or not you need to hire a wallpaper stripper.
- You can buy wallpaper stripping solution from DIY stores, but a 50/50 mix of warm water and vinegar will work just as well at a fraction of the cost.
- Don't soak too much of the paper at one time, or it will dry before you get to stripping it.
- If you are using a steamer, don't hold the plate to the wall for longer than 10 seconds. Doing so could damage the plaster.



Decorating Guide

How to paint

Difficulty: 

Time needed: Varies

Tools



Brushes

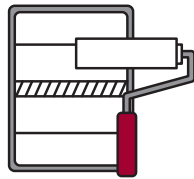

Roller and tray

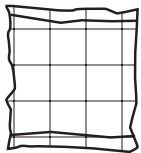

Damp cloth



Paints



Watch the video

Warning:

Make sure you have adequately protected carpets, furniture and woodwork before you start

Step-by-Step Instructions

1. Some paints need to be stirred before you use them, so check the tin before you start. Once the paint is ready, pour some into the deep end of your roller tray (if you're using a roller).
2. Dip your brush or roller into the paint. To prevent dribbles, wipe off any excess paint (on the inside edge of the tin or in the shallow part of your roller tray).
3. Brush or roll the paint using straight, even strokes. Use a combination of horizontal and vertical strokes for the smoothest finish.
4. If you're using a roller, you will still need a brush for any edges and corners, as the roller won't reach them.
5. After you've finished a complete coat, let the paint dry before deciding if you need a second coat. Don't forget that the paint will look slightly different when dry, so don't panic if it doesn't look right while you're painting.
6. Your paint tin should have instructions on how to clean your brushes. It will also have guidelines on how long the paint will take to dry.
7. Wait until the paint is completely dry before you start putting the room back together.

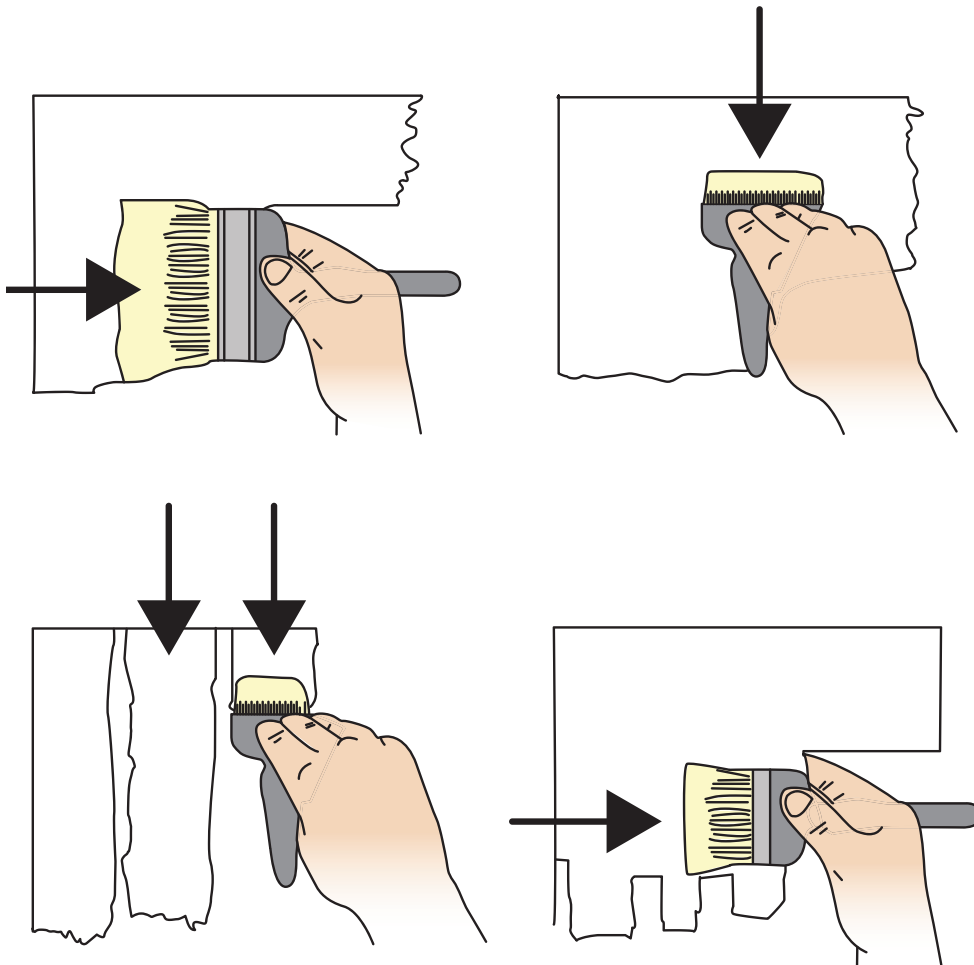

Top Tips

- Different surfaces require different types of paint, as follows:

Type of surface	Type of paint
Interior walls	Water-based paint (emulsion), available in matt or gloss finishes.
Woodwork	Wood stain or oil-based paint. If painting, you may also need a primer to help the paint stick.

- You can buy special paint for bathrooms and kitchens that can be wiped down. When these rooms get steamy, you can wipe the walls to prevent mould growing on condensation
- For best results, make sure you follow the manufacturer's instructions when using paint.



Decorating Guide

Mastic baths, basins and sinks

Difficulty: ● ● ● ● ●

Time needed: Varies

Tools



Silicon

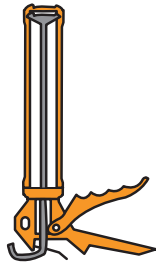

Skeleton gun

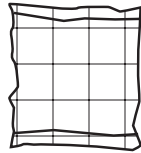

Clean cloth



Step-by-Step Instructions

1. Ensure all of the surfaces you are silicong are very clean and smooth, soap or residue will stop the silicone from adhering properly.
2. Insert the silicone into the skeleton gun by pulling back the central bar, insert the silicone tube and holding the sprung lever push the central bar into place so it's contacting the end of the silicone tube.
3. Cut a nice clean angle on your tube spout, about 30 degrees and make sure you use a sharp blade as any ragged edges will reflect in your silicone.
4. Have water to hand beside the area you are working, this should be used for dipping your finger in to smooth the silicone, after application.
5. Have a clean fresh cloth handy for cleaning excess silicone off your finger/gun.
6. Position yourself so that you can do full runs without stopping or trying to walk along at the same time.
7. Pressure the gun trigger so that a smooth constant bead of silicone comes out, adjust your speed of travel to ensure a uniform bead goes down.
8. Remember not to put too much silicone down as it will spread as you smooth it.
9. Depending on the application/finish you require, you can either leave a raised bead or dip a finger in the water and gently run your finger along the bead to push it into the gap and create a smooth hollow in the bead.
10. Remove excess silicone from finger with a clean cloth prior to continuing.

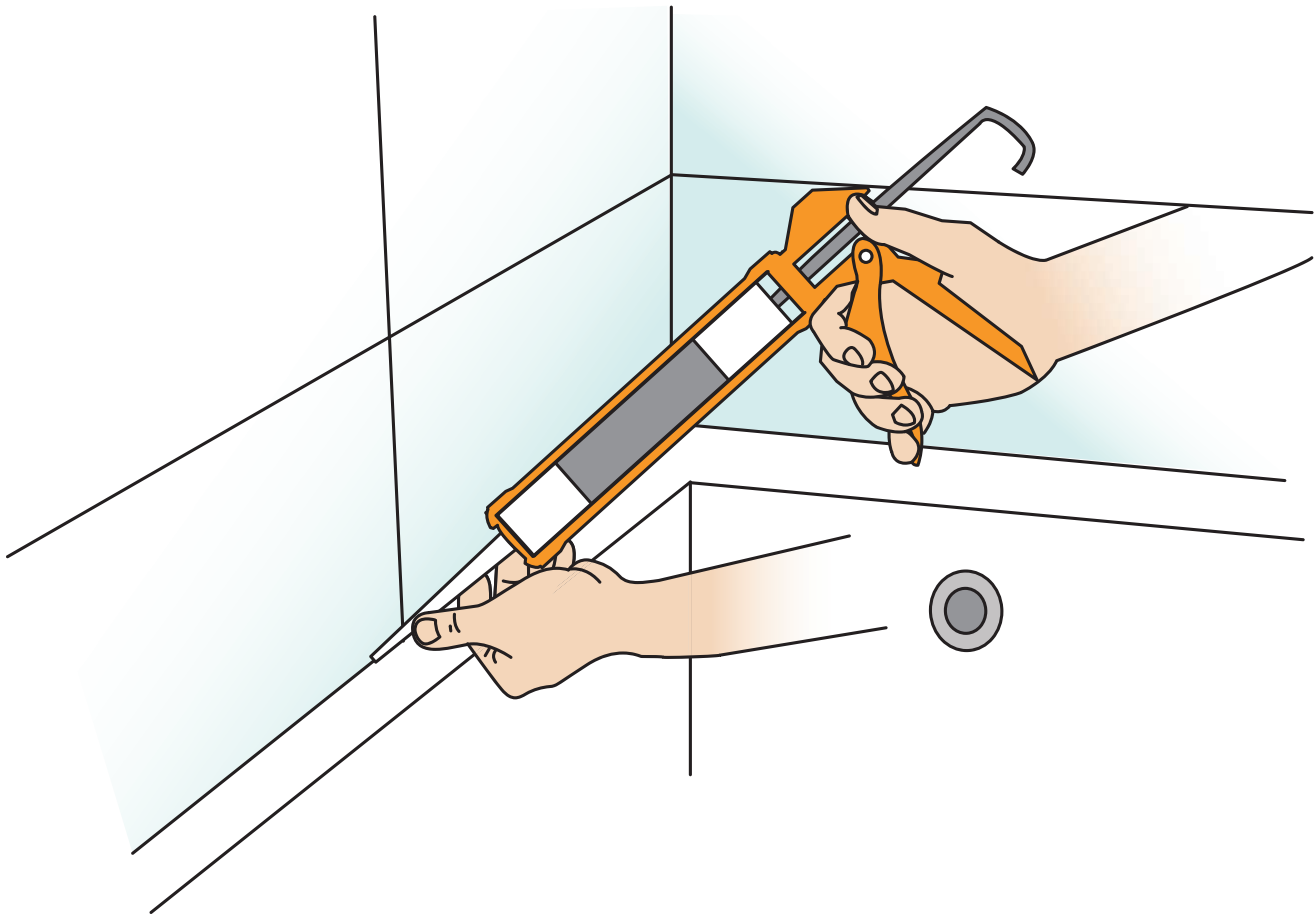

Top Tips

1. Wrap your tube of silicone with tape to prevent it expanding with the pressure of the skeleton gun - this helps the gun stop as soon as you click the release catch instead of running on. Brown parcel tape is ideal for this as it does not stretch easily.
2. Do not cut the end too large as uncontrollable floods of silicone will come out and make a mess
3. Ensure any old silicone or residue is removed before applying new silicone.
4. If applying silicone to a bath half fill the tub with water to weigh it down to ensure the silicone doesn't get stretched / pulled off the wall when the bath is filled.

Axis

General Advice

How to prevent condensation	78
How to look after your home	80
How to save energy and water	82





General Advice

How to prevent condensation

Difficulty: 

Time needed: n/a

Step-by-Step Instructions

1. Don't let excess moisture accumulate. The main sources of moisture in your home will be cooking, showering or bathing a family of four creates 6 pints of water per day in the home. When using the kitchen or bathroom, try to keep the doors closed and windows open. Keep your home ventilated by opening windows as often as you can and keeping any vents clear. Finally, wipe surfaces where steam condenses (e.g. kitchen cupboards, walls and ceilings around showers), to prevent mould from forming.
2. Cut down on the moisture you produce. If possible, dry clothes on an airer in the bathroom or other well ventilated room. Do not dry clothes on radiators. Cover your pans with lids when cooking. If you have a tumble drier, make sure it vents outside.
3. Keep your house warm. Try to keep up a low level of heat throughout your home during cold months, especially upstairs and in the areas next to your bathroom and kitchen. Effective draught proofing and insulation will also help keep heat in your home.

Top Tips

- Condensation is caused by moist air coming into contact with cool surfaces, like walls, tiles and glass.
- Because heat rises, warm air often condenses on or near the ceiling and it will also travel upstairs. If left unchecked black mould will eventually grow where the moisture has gathered.
- The main sources of moisture in your home are cooking, showering and bathing, and using gas.
- Mop up condensation every day to make sure black mould does not grow as a result of condensation.
- Clean up black mould with a mould cleaner or diluted bleach solution.
- Running your heating for longer periods at a lower temperature can also help.

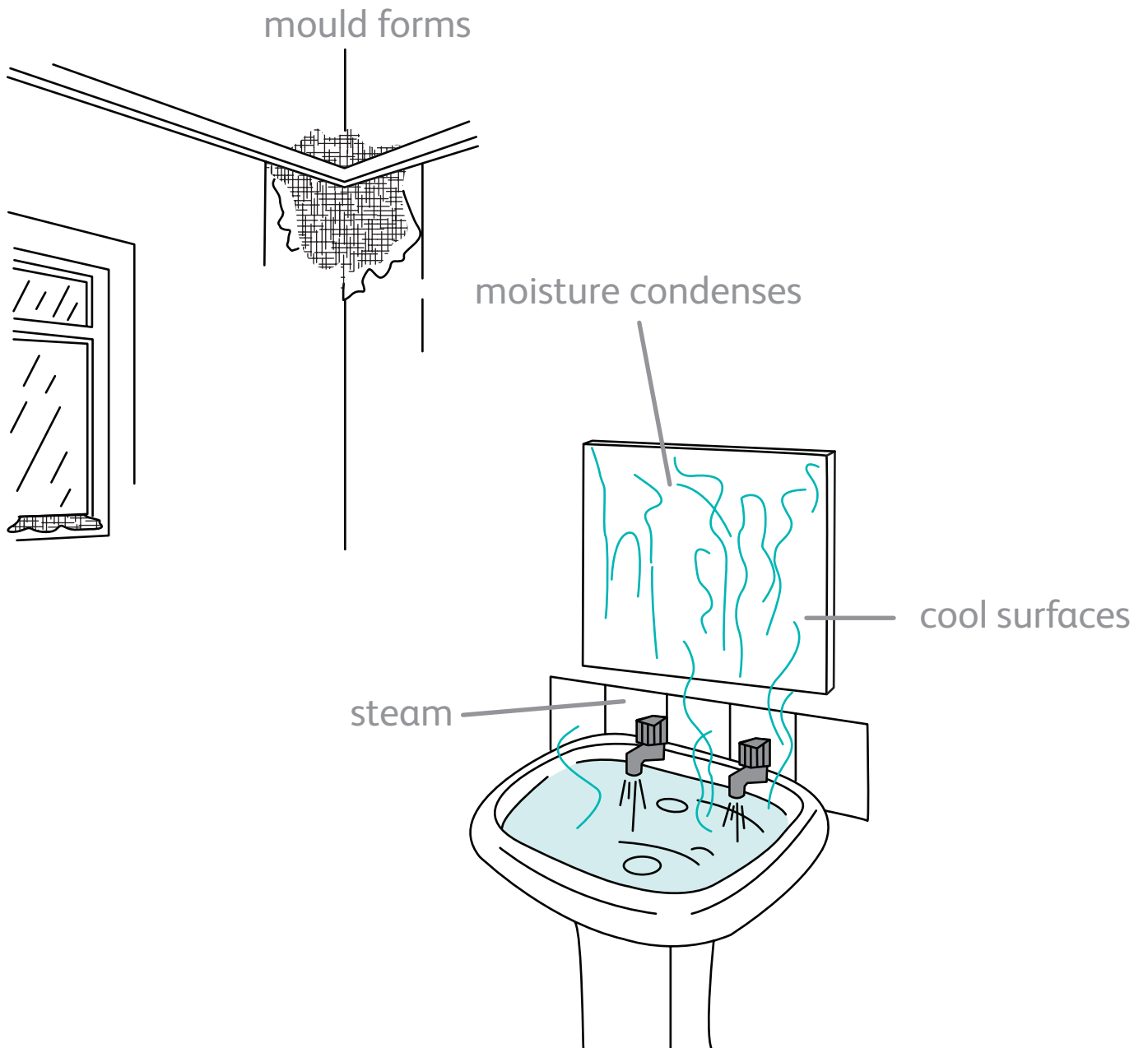



General Advice

How to look after your home

Difficulty: 

Time needed: n/a

Step-by-Step Instructions

One way to cut down on home repairs is to take preventative action. Doing these simple maintenance jobs and checks could save you a big headache and a lot of money.

Regular home maintenance jobs

1. Wipe your window cills clear of condensation.
2. Keep sinks clear with clearing solution.
3. Use descaling solution on kettles and taps.
4. Clear the leaves and rubbish from your drain gullies.
5. Oil your hinges and locks on doors and windows.

Regular household checks

1. Make sure your stoptaps and gate valves are easy to turn or report to Kingston Council.
2. Keep an eye out for damage to the tiles or slates on your roof.
3. Check that your gutters and pipes aren't leaking or blocked.
4. Check smoke alarms.

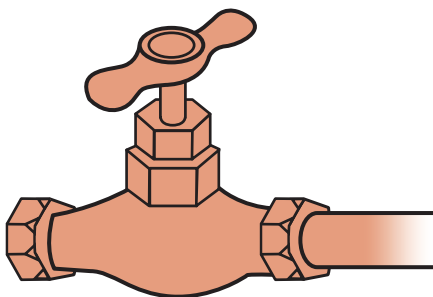

Stoptap

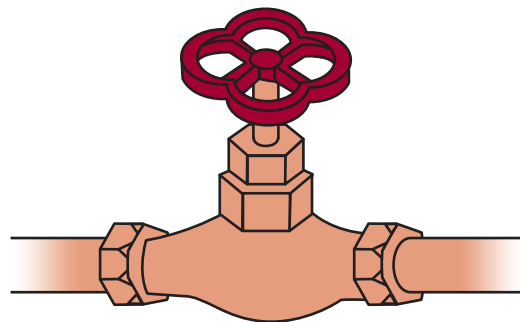

Gatevalve

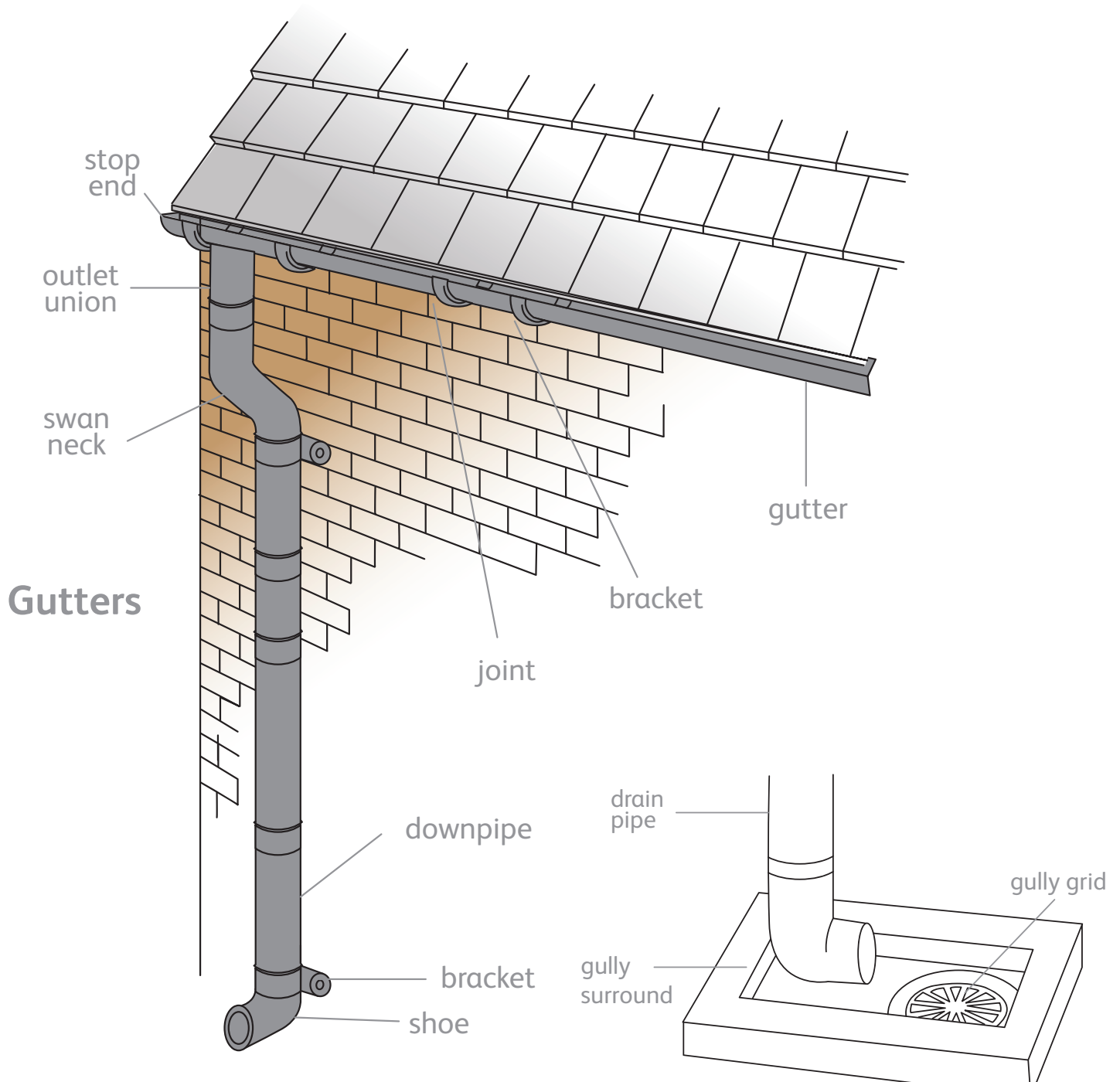



General Advice

How to save energy and water

Difficulty: 

Time needed: n/a

Saving energy and water has a lot of benefits. Cutting out wasted energy saves you money on your utility bills. Household energy use accounts for roughly 25% of our CO₂ emissions, so saving energy can also protect the environment.

Saving water

- Keep your taps in good working order. Dripping taps waste money and energy, so stay on top of your taps. Change the washers regularly and don't leave one to drip for weeks.
- Showers use less water than baths, so try to use a shower if you have one.
- Don't leave taps running while you brush your teeth or do the dishes.
- Try to avoid half-filling your washing machine. If you can, wait until you have a full load.
- If you wash your car, use a bucket of water instead of a hose.
- If you have a garden, you could collect rainwater in a water butt and use this to wash your car and water your plants.

Saving electricity and gas

- Energy efficient bulbs might be more expensive than regular bulbs, but they can last 12 times longer and use less electricity. By the time they burn out, they more than pay for themselves.
- When leaving a room, switch off the lights and turn off electrical devices at the socket. Even on standby, your appliances are using electricity.

- Try to avoid charging phones, laptops and other electrical devices overnight, as they will continue to use electricity even when fully charged.
- Make sure the thermostat on your boiler is set no higher than 60 degrees. Heating your water beyond this temperature is a total waste of energy.
- Fully loading your washing machine not only saves water, it also saves energy. If you can, dry your clothes outside. They will smell nicer, you'll get less condensation in your home and you'll save a lot of electricity.
- Don't overheat your home. Keep the heating as low as you comfortably can. Good draught proofing will help keep the heat where you want it, so you won't need to use as much energy to heat your home.
- Think about how you use your fridge and freezer. Don't put them next to a heat source (e.g. cooker, radiator). Try to avoid putting warm or hot food in your fridge or freezer. Also, try to keep both as full as possible. Even filling gaps with newspapers in plastic bags is more fuel efficient than leaving your fridge half empty.

